

Benefits

- ❖ Switches set to specific rising or falling pressures
- ❖ UL recognised versions available
- ❖ High performance repeatability

- ❖ Single or double pole switching
- ❖ Customised settings available upon request
- ❖ Various connector options available

Silver Contact Microswitch Data

Average Life Expectancy	Mechanical	1.0 x 10 ⁶		
	Electrical	2.0 x 10 ⁵ @ 10A 1.0 x 10 ⁴ @ 21A		
Electrical Rating	Max. Electrical Load			
	Voltage	Res.	Ind.	(Pf 0.75 Motor)
AC	250V	21A		1HP
	250V	21A	8A	1HP
	125V	21A		
DC	6V	21A	21A	
	12V	15A	15A	
	24V	8A	7A	
	60V	1A	0.5A	
	110V	0.5A	0.1A	
	220V	0.25A	0.1A	

Model No	6742-20/30/40/50/60	6742-70/80/90
Electrical Switch Data	2 Pole change over	2 Pole Change over
Contact Rating	21 (8) A 250V ac	21 (8) A 250V ac
Pressure Connection	Brass 1/8" BSPT	Brass 1/8" BSPT
Setting Accuracy	± 10% as standard	± 10% as standard
Withstand Pressure	25 PSI or x 2	150 PSI 10 Bar
Temperature Range	-5°C to + 70°C	-5°C to + 70°C
Body Material	Nylon 12	Nylon 12
Diaphragm	Neoprene	Nitrile fabric reinforced fitted in brass pressure capsule
Spring	Spring steel	Spring steel
Weight	50gm	85gm

Gold Contact Microswitch Data

Average Life Expectancy	Mechanical	1.0 x 10 ⁶		
	Electrical	2.0 x 10 ⁵ @ 10A 1.0 x 10 ⁴ @ 21A		
Electrical Rating	Max. Electrical Load			
	Voltage	Res.	Ind.	(Pf 0.75 Motor)
AC	250V	0.1A	0.05	N/A
UL/CSA Only	125V	0.1A	-----	-----

Model No	Pressure Range		Differential (Fixed)
	P.S.I	Bar	
6742-20	1.5 - 3.5	0.10 - 0.24	See chart 1
6742-30	3.0 - 5.5	0.20 - 0.37	See chart 1
6742-40	5 - 10	0.34 - 0.68	See chart 1
6742-50	8 - 18	0.54 - 1.22	See chart 2
6742-60	16 - 30	1.08 - 2.04	See chart 2
6742-70	25 - 55	1.70 - 3.79	See chart 3
6742-80	45 - 75	3.1 - 5.17	See chart 3
6742-90	60 - 120	4.14 - 8.27	See chart 3

Switch Standards: EN 60730, EN 61058 and UL 508

Approvals Available: CE, BEAB, CSA, DEMCO, IMQ, KEMA, NEMCO, OVE, SEMCO, SET I, SEV, UL, VDE

NB

Herga do not accept liability for any pressure operated device used outside the pressure range specified by the company.

Special options are available for quantity orders

- ❖ Diaphragms in silicon rubber, nitrile, EPDM
- ❖ Switches with wide or close differentials
- ❖ Springs in stainless steel
- ❖ NPT connectors available

Suitability for use with different operating media

Pressure Medium	Diaphragms	
	6742/20/30/40 50 & 60	6742/70/80 & 90
Chemical Compatibility		
Acetone	✓	✓
Ammonia (Liquid)	✓	✓
Amyl Alcohol to 20°C	✓	✓
Automotive Brake Fluid	✓	✓
Beer	✓	✓
Benzyl Alcohol	✗	✓
Butane	✓	✓
Carbon Dioxide - Dry	✓	✓
Citric Acid	✓	✓
Copper Sulphate (Sol.)	✓	✓
Compressed Air	✓	✓
Cutting Oil	✓	✓
Diesel Oil	✓	✓
Detergent Solution	✓	✓
Fuel Oil	✓	✓
Glycol	✓	✓
Hydraulic Oil	✓	✓
Hydrogen	✓	✓
Lubricating Oil	✓	✓
Milk	✓	✓
Mineral Oil	✓	✓
Natural Gas	✓	✓
Nitric Acid (Dil.)	✗	✓
Oxygen to 70°C	✓	✓
Petrol	✓	✓
Plating Solution (Chrome)	✓	✓
Salt Water	✓	✓
Sewage	✓	✓
Sulphur Dioxide	✗	✓
Turpentine	✓	✓
Vinegar	✓	✓
Water	✓	✓

Key: ✓ = Recommended
 ✓ = Suitable with modification
 ✗ = Not suitable

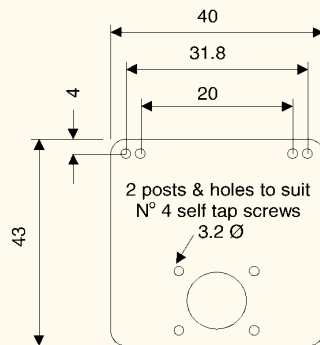

2mm thick mounting plate
 Part N° 3351-109
 for 6742-20 to 6742-60

Note:
 Longer screws will penetrate
 diaphragm chamber, please order
 part N° 2112-643-047 Qty 2

Alternative Pressure Connections 1/8" NPT Pressure Connector

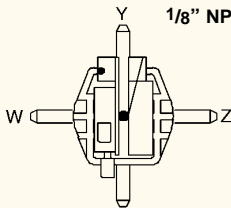

Non standard tube connection
 positions for 4mm Ø spout connection.
 Not recommended for pressure
 over 20 PSI

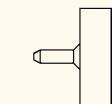

Back entry
 6.4mm Ø spout

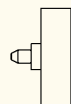

Back entry
 4mm Ø spout

6742-20 to 6742-60 only

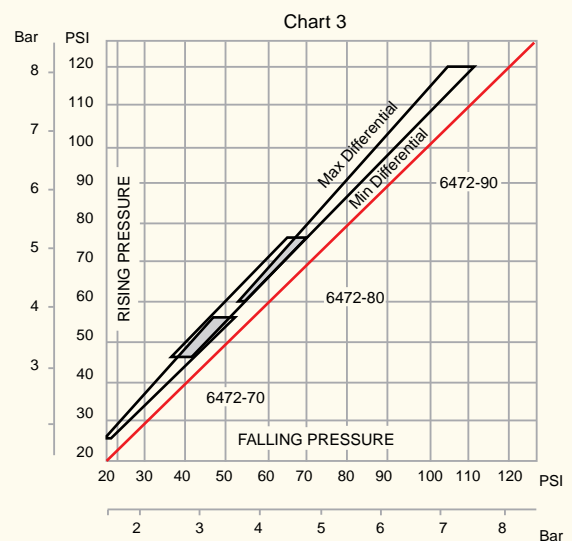
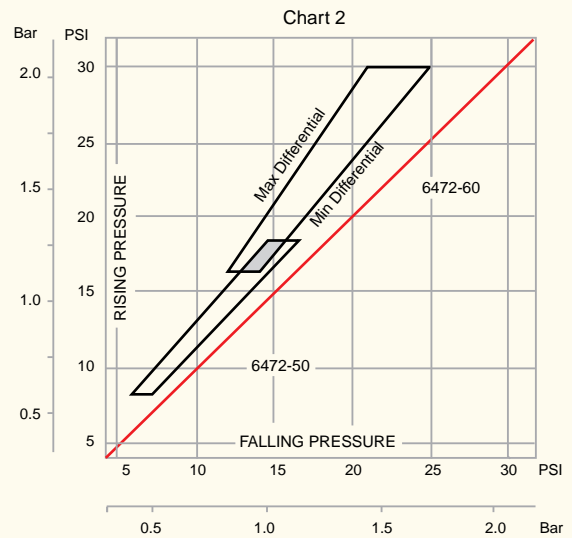
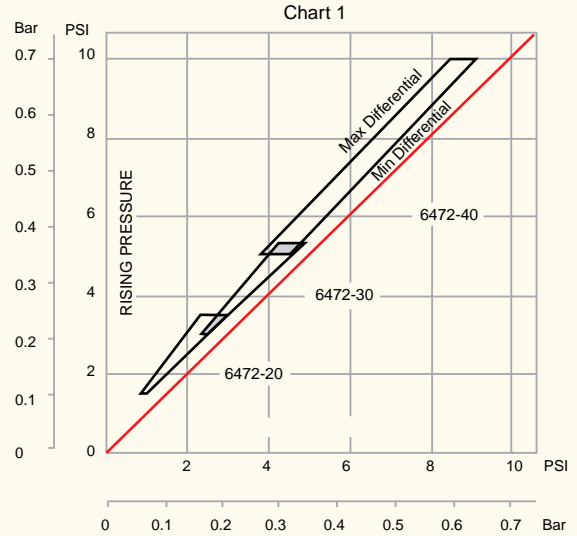

Note: Differentials are approximate