

TOGGLE SWITCHES

PRODUCT NUMBER 0145.1220



TECHNICAL DATA

Product number	0145.1220	
Actuator color / printing		
Product family	Toggle switches	
Actuation type	direct	
Weight	28.000 g	
ROHS conform	yes	
Switching function	ON / OFF switch (DPST)	
Material fixed contact	Ag	
Number of poles	2 - pole	
connections	Socket terminal, M3	
Mechanical life endurance	5E4	
Rating IEC	6 (4) A 250 V AC 4 A 250 V DC 5E4	
Rating North America	10 A 125 V AC-DC 6 A 250 V AC-DC	
Actuators and additional actuators	lever: PA, black with red point	
Housing description	bracket plate: Duroplast (base) / chromated galvanized steel (bracket plate), with labelling 0 intermediate plate: PA, black base plate: natural threaded socket: CnZn nickel-plated, without knurled nut with round nut	
Connection surface	→ bearing connection	chromated
	→ external connection	chromated
Contact material	Ag	
Rating Code UL	R 45	
Contact type	jump contact (knife contact)	

Approval marks	CSA / UL / ENEC 05
Suitable for appliances of protection class	II
Additional labeling	year/week of manuf. acc. to DIN EN 60062
Type of fastening	central fastening M12 x 0.75
Degree of pollution	3
Stock version	●

PRODUCT IMAGE



DRAWINGS

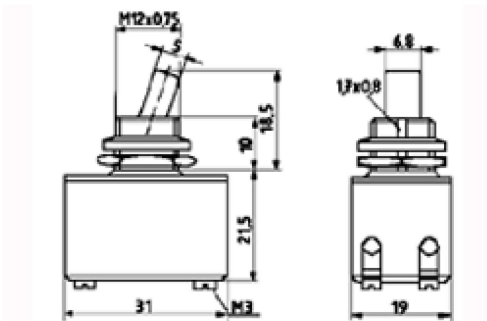

Technical changes reserved. Dimensions are not binding.
Detailed specifications available on request.

Marquardt Verwaltungs-GmbH · Niederlassung Schaffhausen · Ernst Müller-Str. 7 · Postfach 952 · CH-8201
Schaffhausen · Switzerland
Phone: +41 (52) 644 30 00 · Fax: +41 (52) 644 30 60 · www.marquardt.ch · marquardt@marquardt.ch