

Unterteil flach, Ausf. I  
Innenansicht  
Bottom part flat, vers. I  
inside view  
B 40 46 707

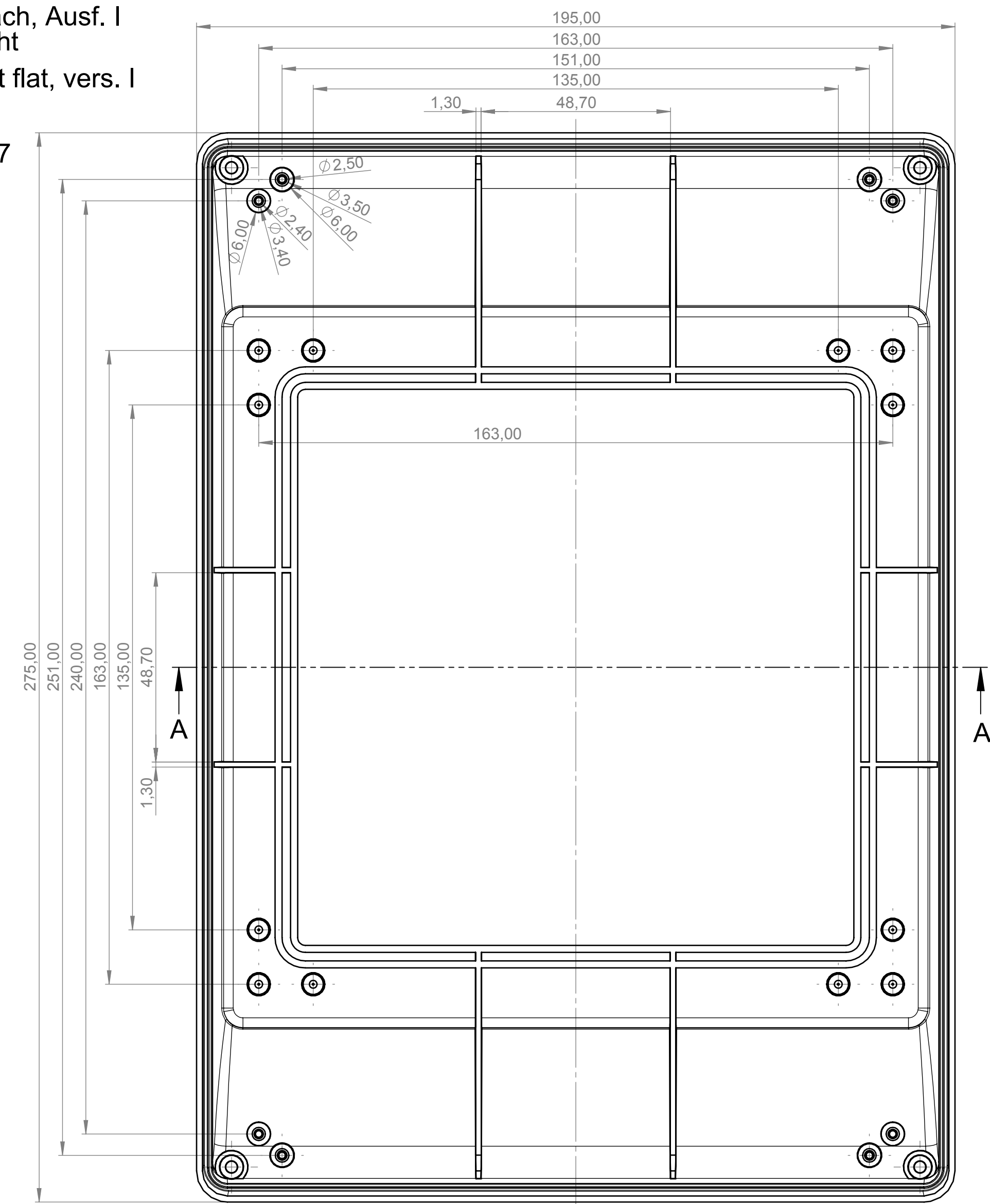

Oberteil  
Aussenansicht  
Cover  
outside view  
B 40 46 407

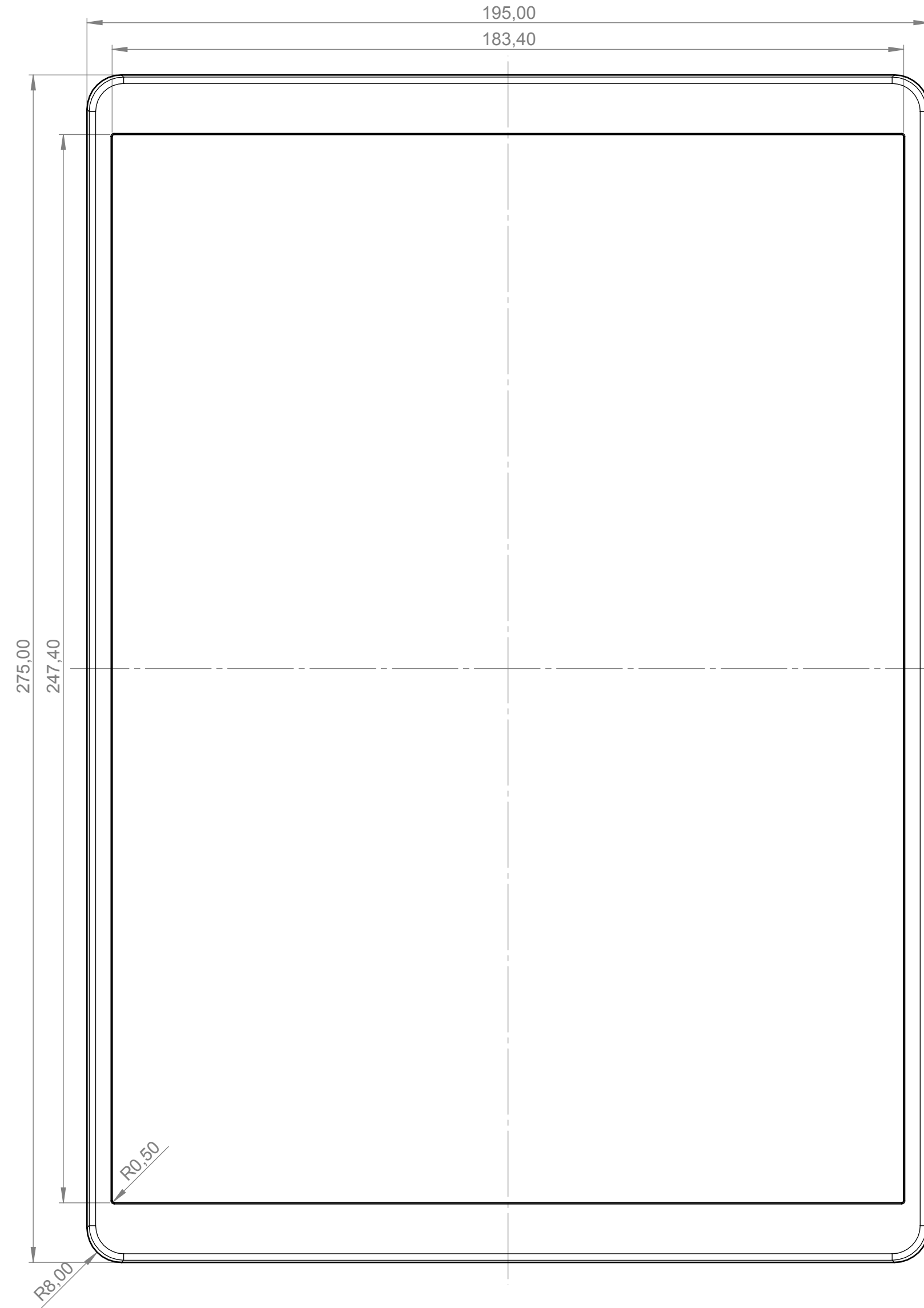

Oberteil  
Innenansicht  
Cover  
inside view  
B 40 46 407

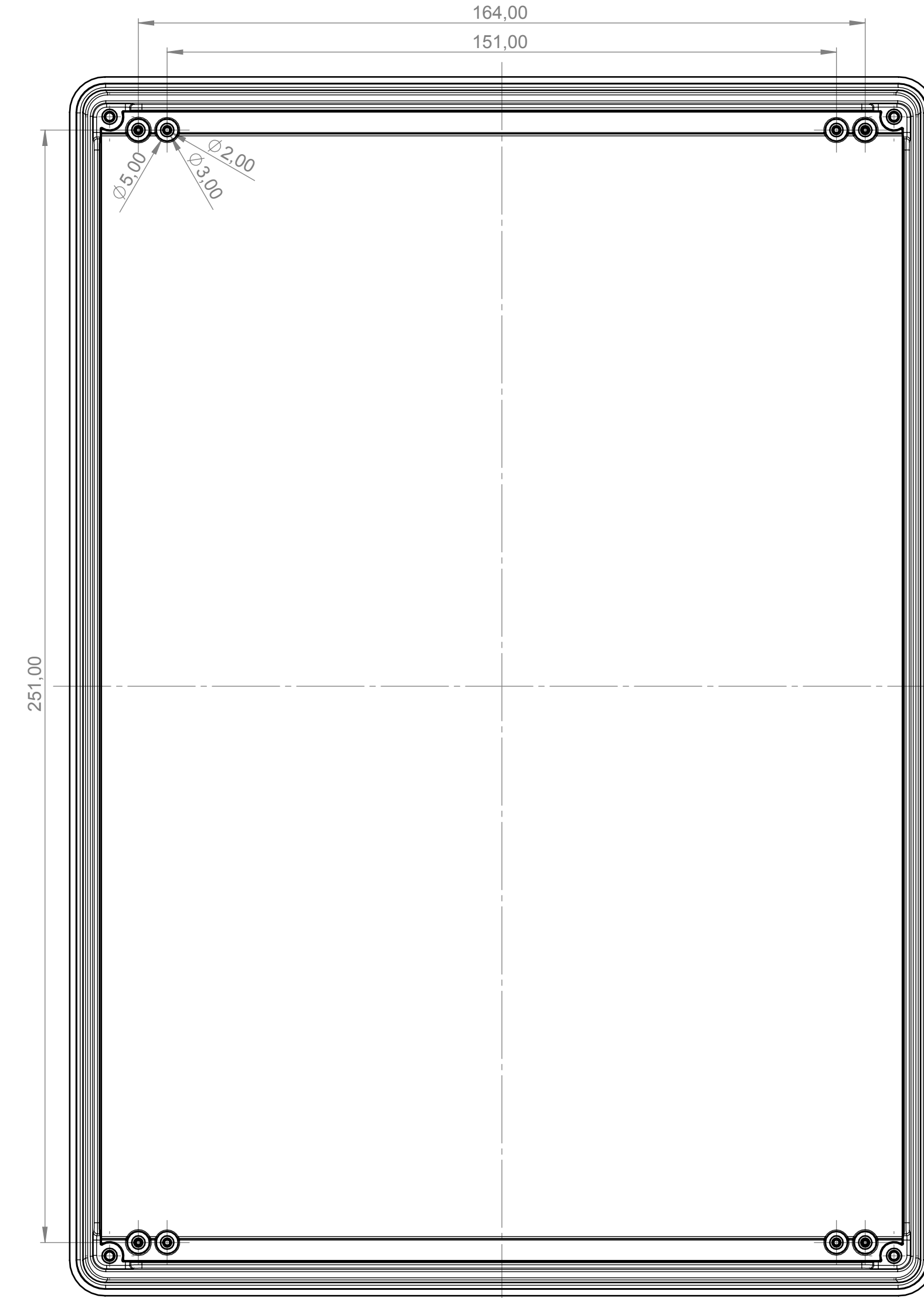

Frontplatte AI  
Front panel AI  
B 41 46 106

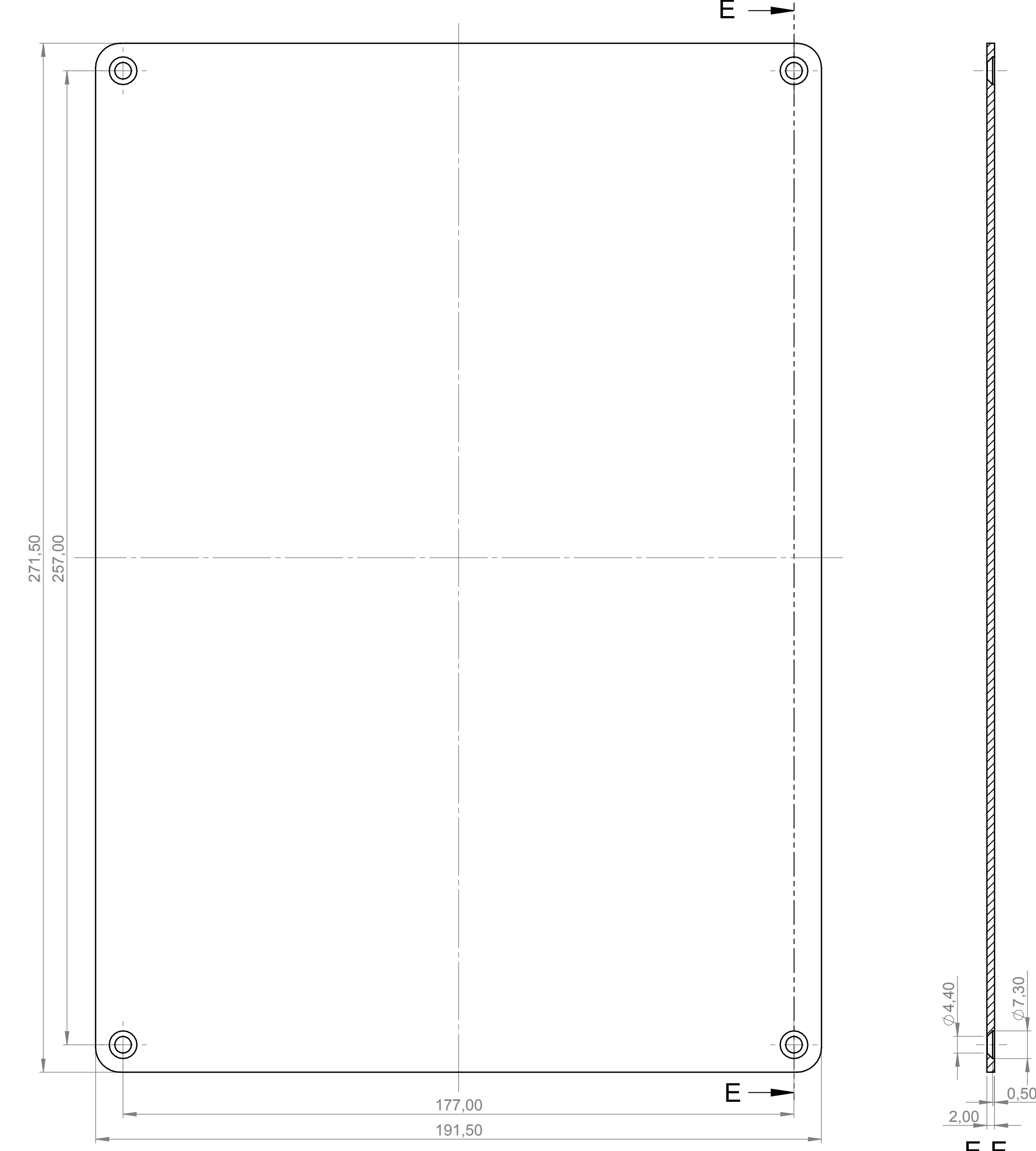

Batteriefach  
Battery compartment  
B 41 46 047

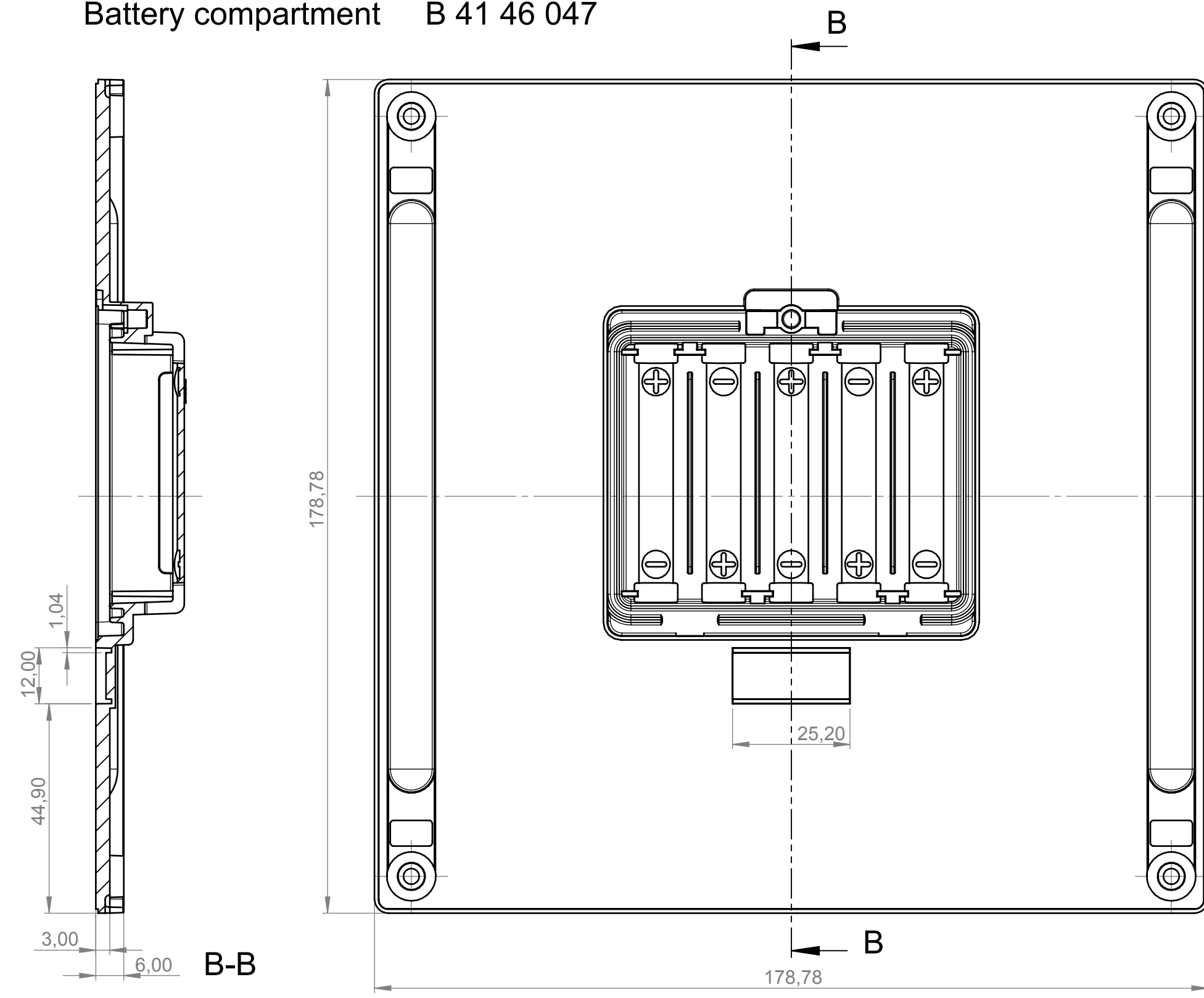

Sockeldeckel für Arretierung  
Base cover  
G

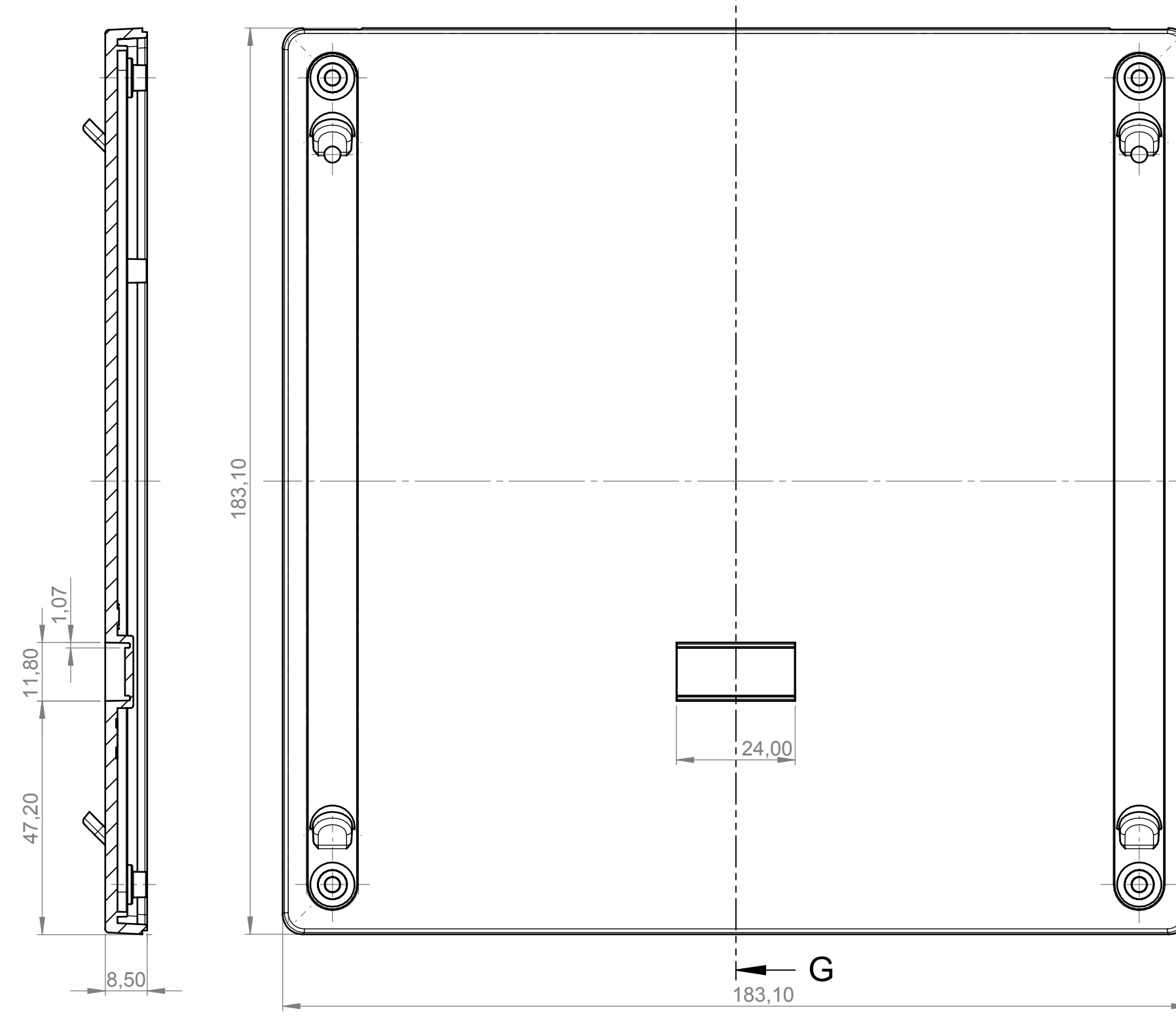

Sockel  
Base  
B 40 46 8\*7

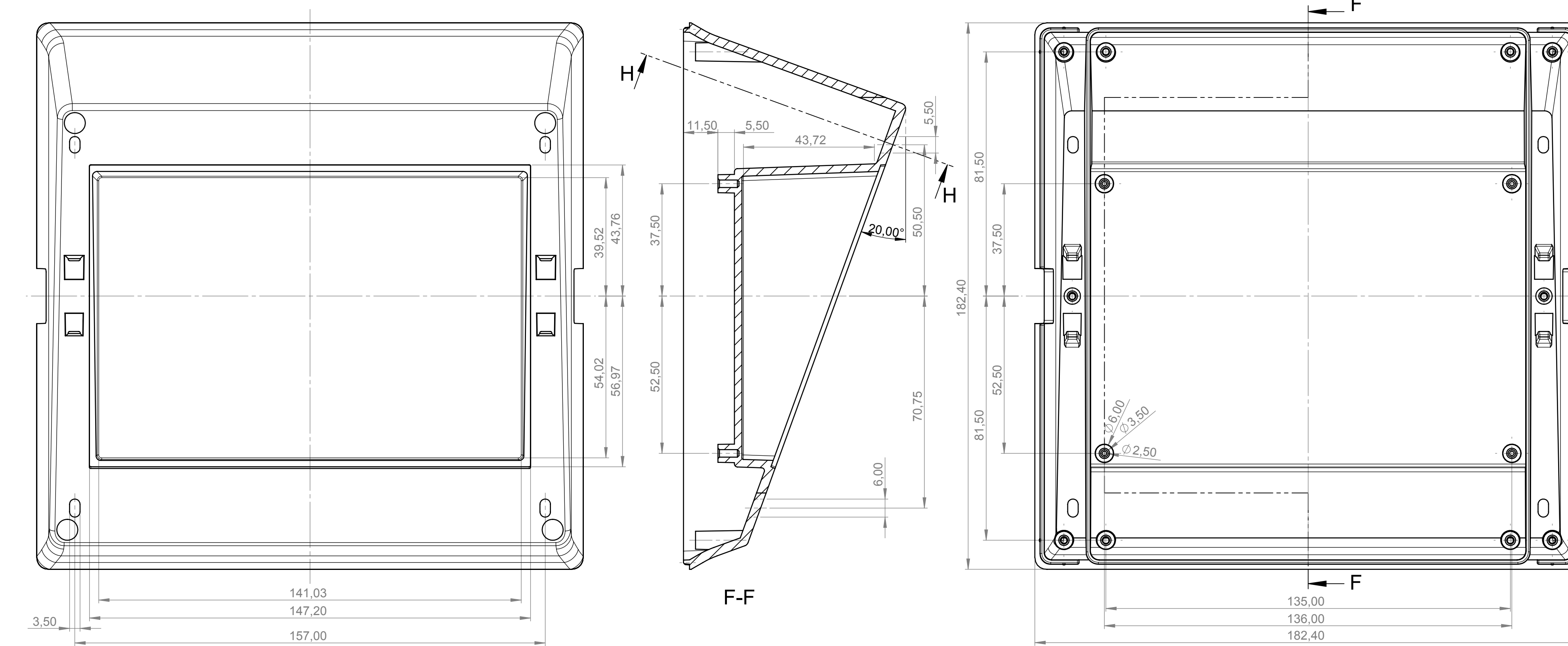

Bodenplatte mit Griffmulde  
Bottom panel with handle recess  
B 41 46 167

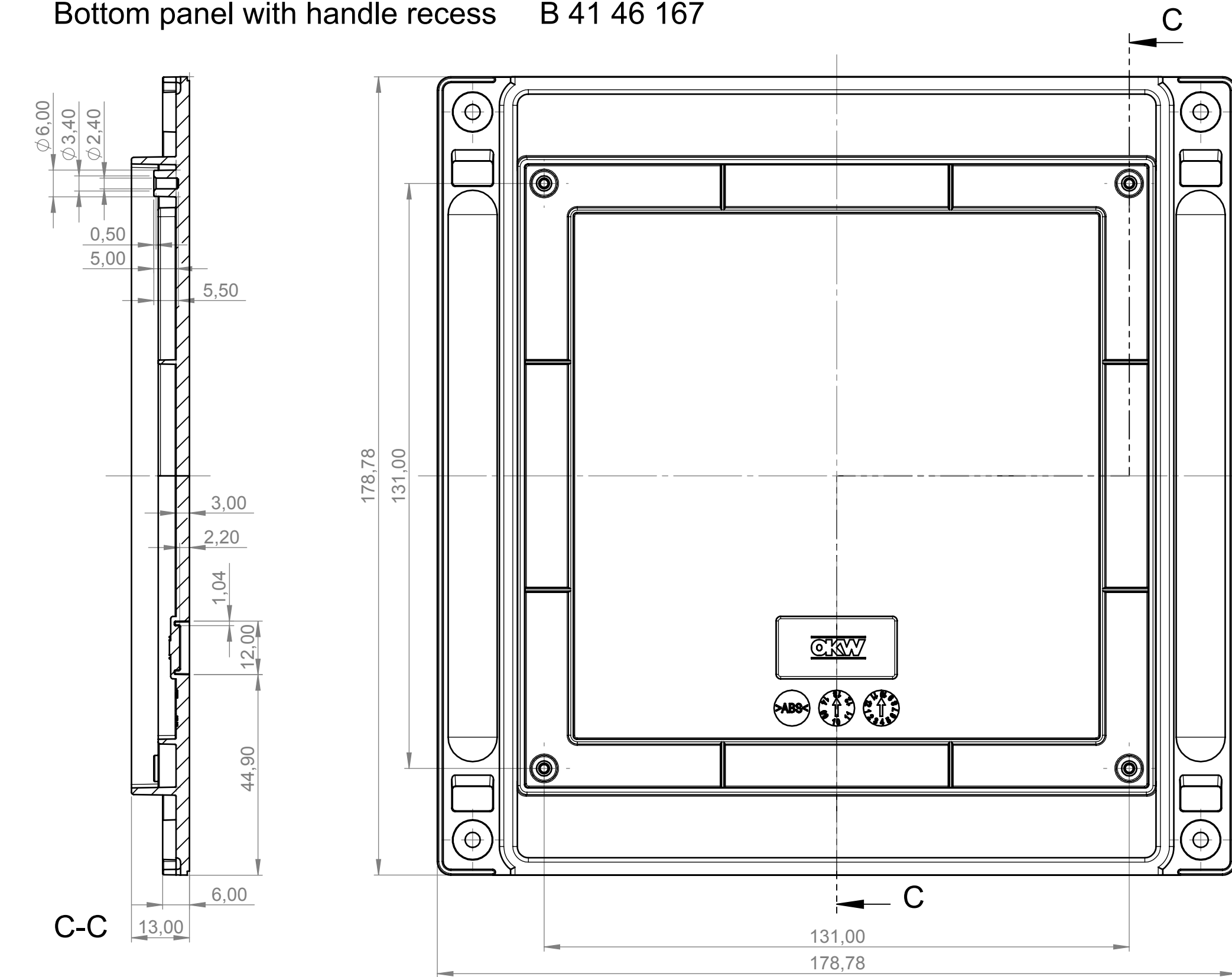

Bodenplatte mit Rastleiste  
Bottom panel with snap-in strips  
B 41 46 257

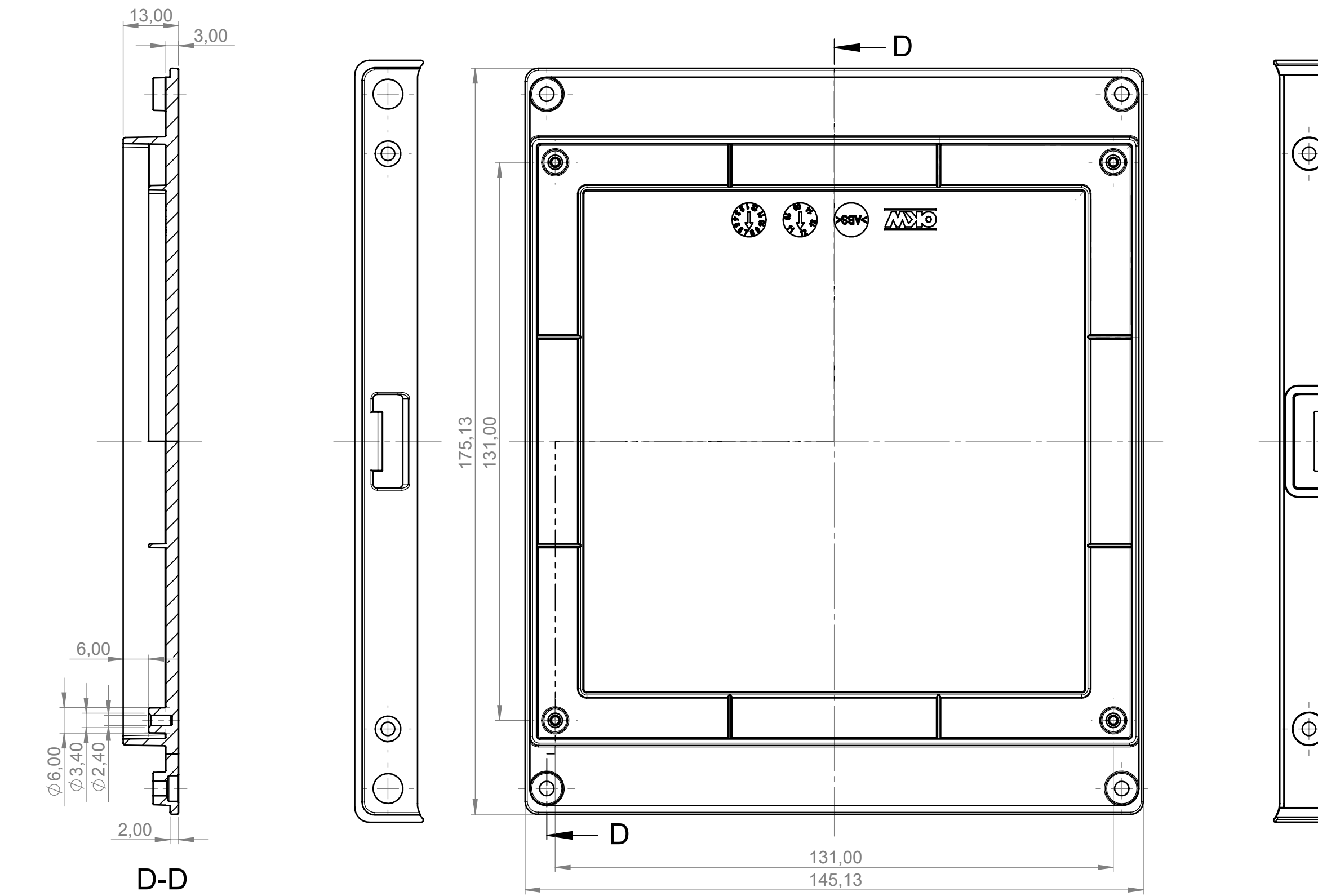

Unterteil flach, Ausf. I  
Bottom part flat, vers. I

Oberteil, Batteriefach, Sockel  
Cover, battery compartment, base

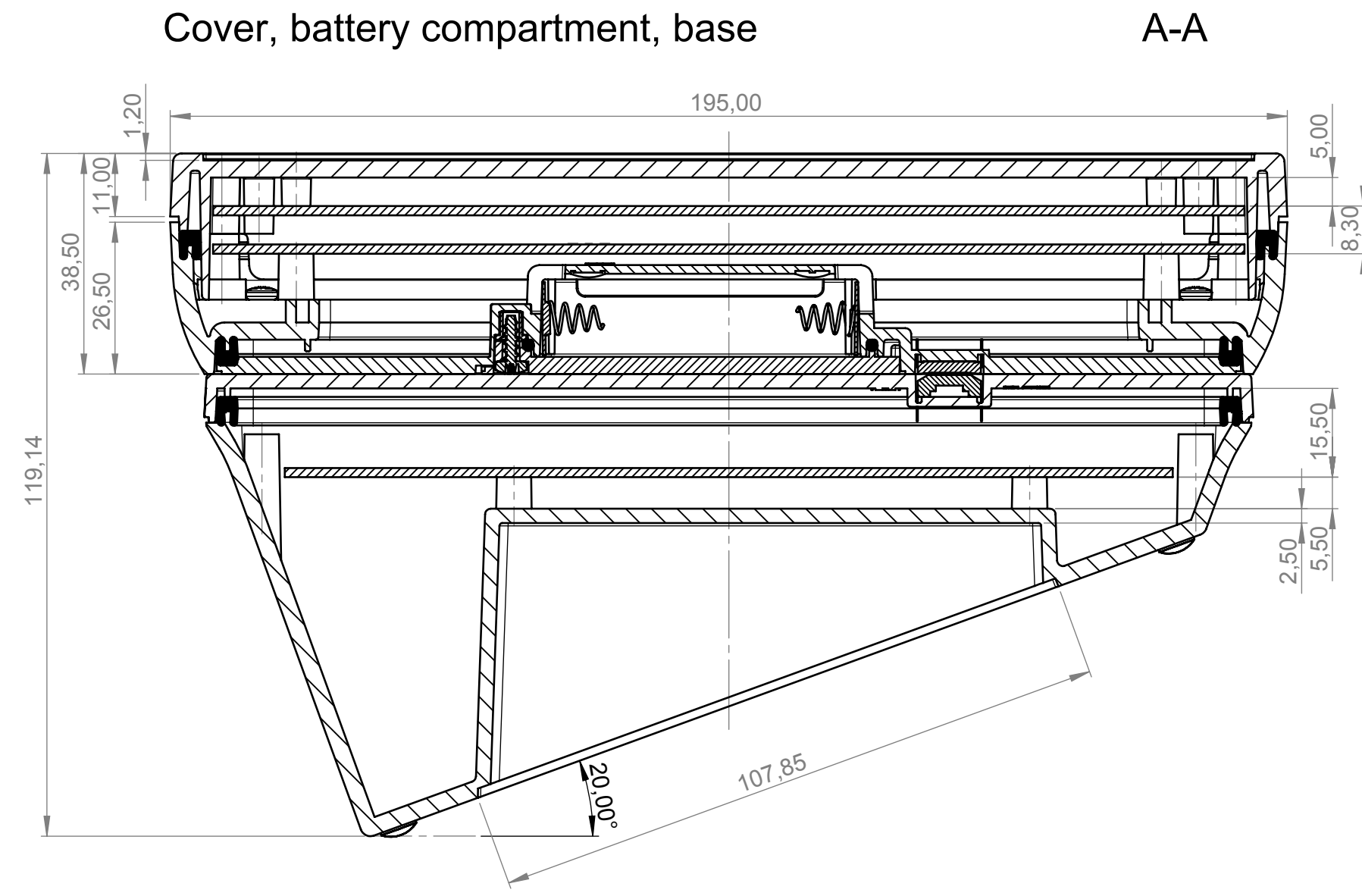

Oberteil, Bodenplatte mit Rastleisten, Sockel  
Cover, bottom part with snap-in strips, base

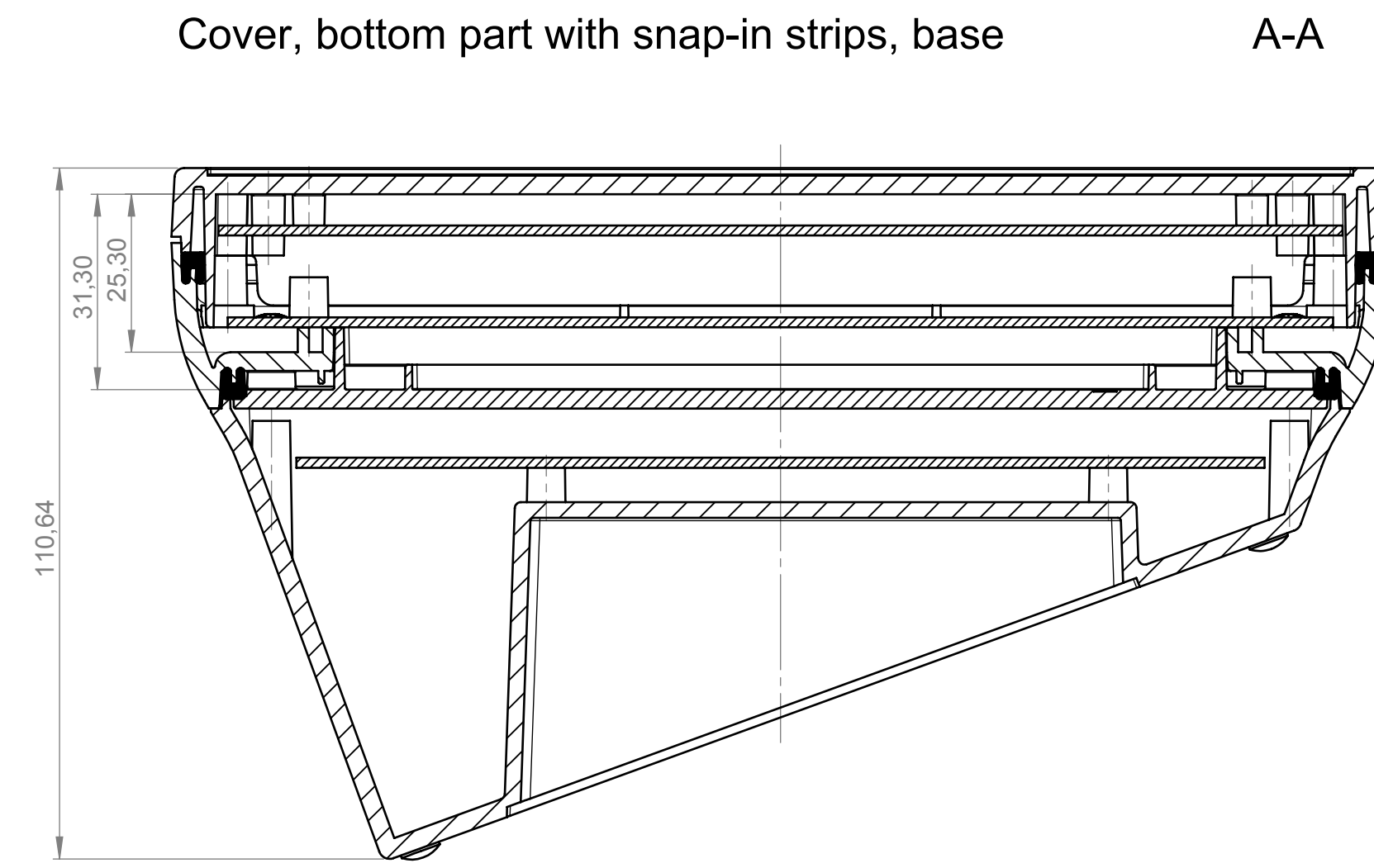

Frontplatte AI, Batteriefach, Sockel  
Front panel AI, battery compartment, base

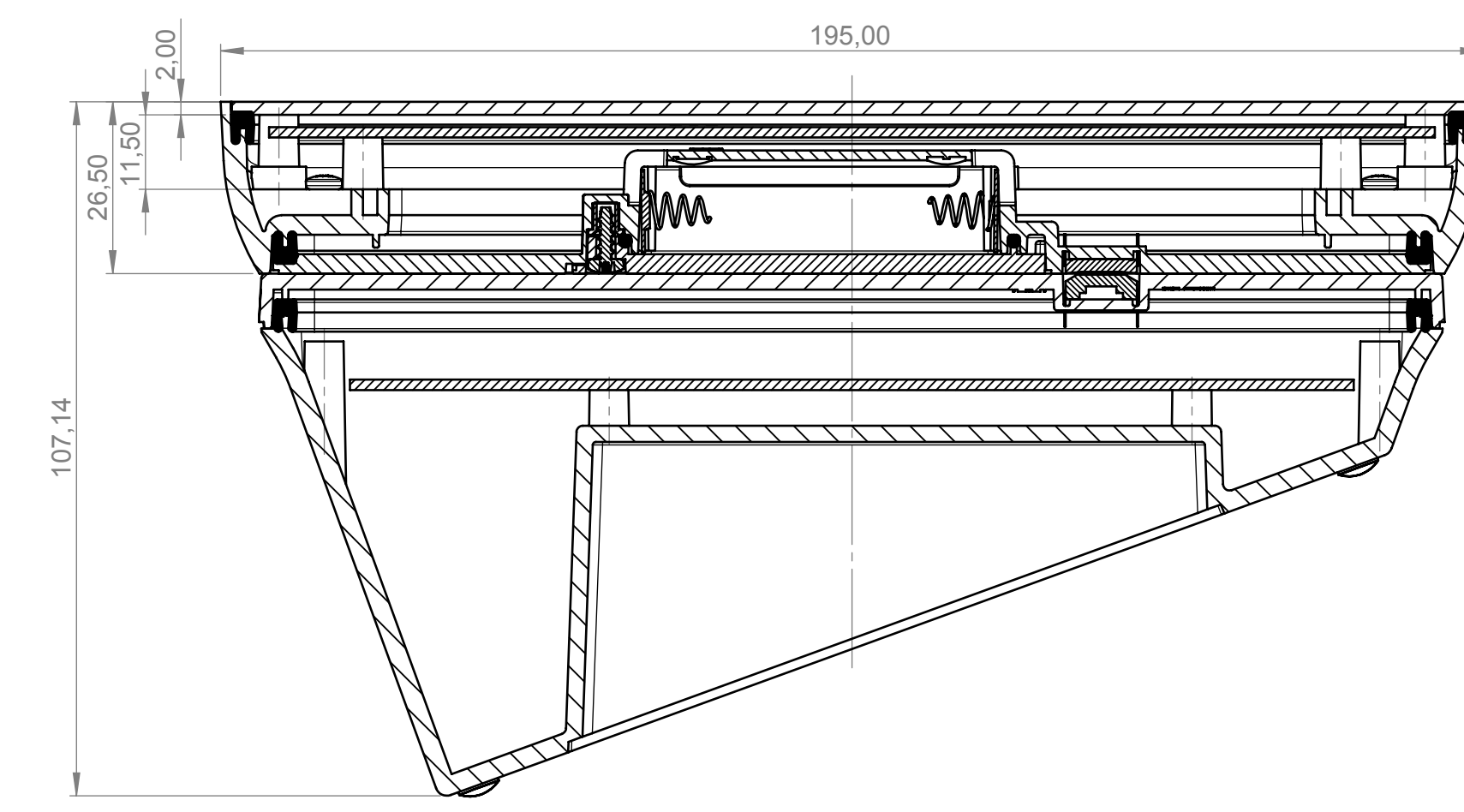

Frontplatte AI, Bodenplatte mit Rastleisten, Sockel  
Front panel AI, bottom part with snap-in strips, base

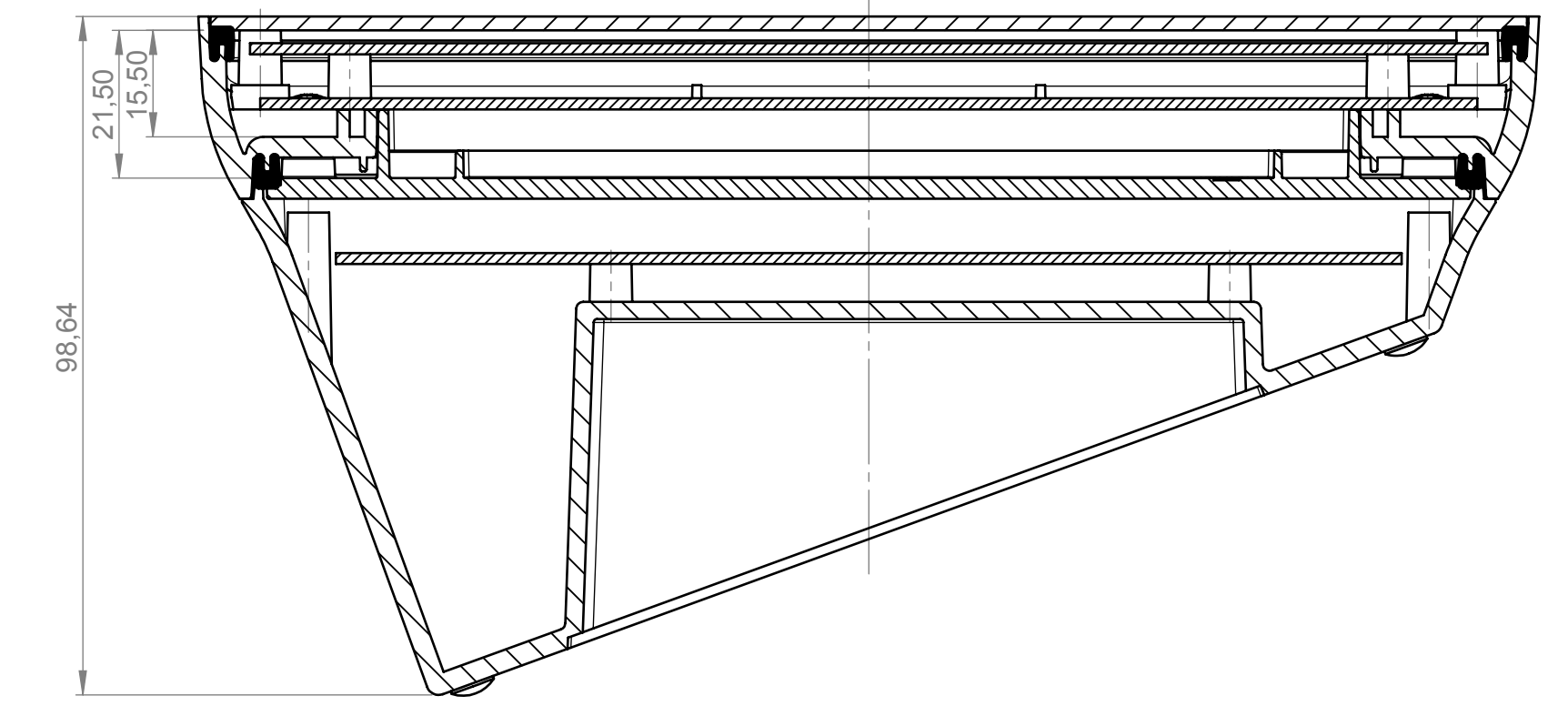

Oberteil, Bodenplatte mit Griffmulde, Sockel  
Cover, bottom part with handle recess, base

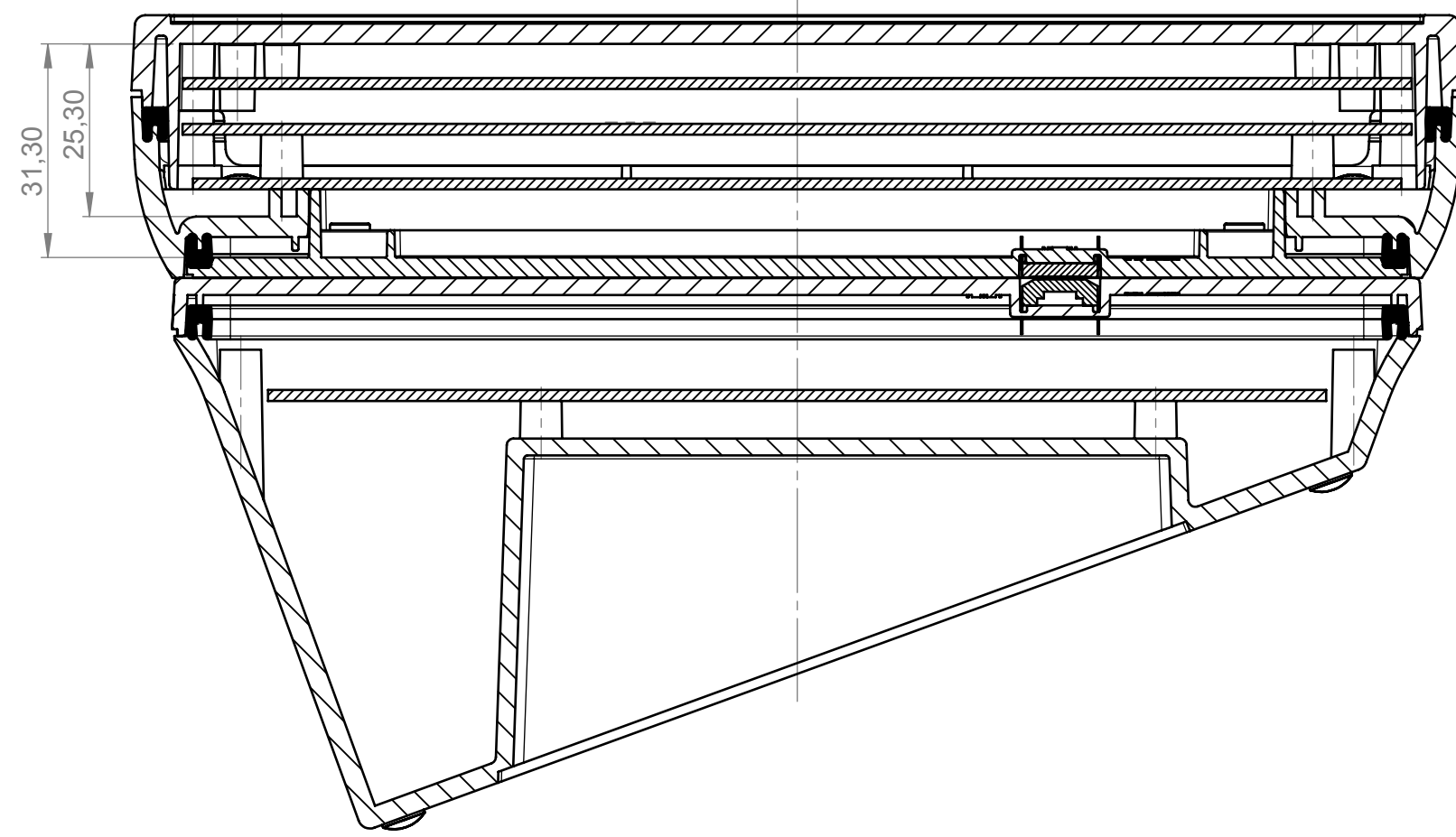

Frontplatte AI, Bodenplatte mit Griffmulde, Sockel  
Front panel AI, bottom panel with handle recess, base

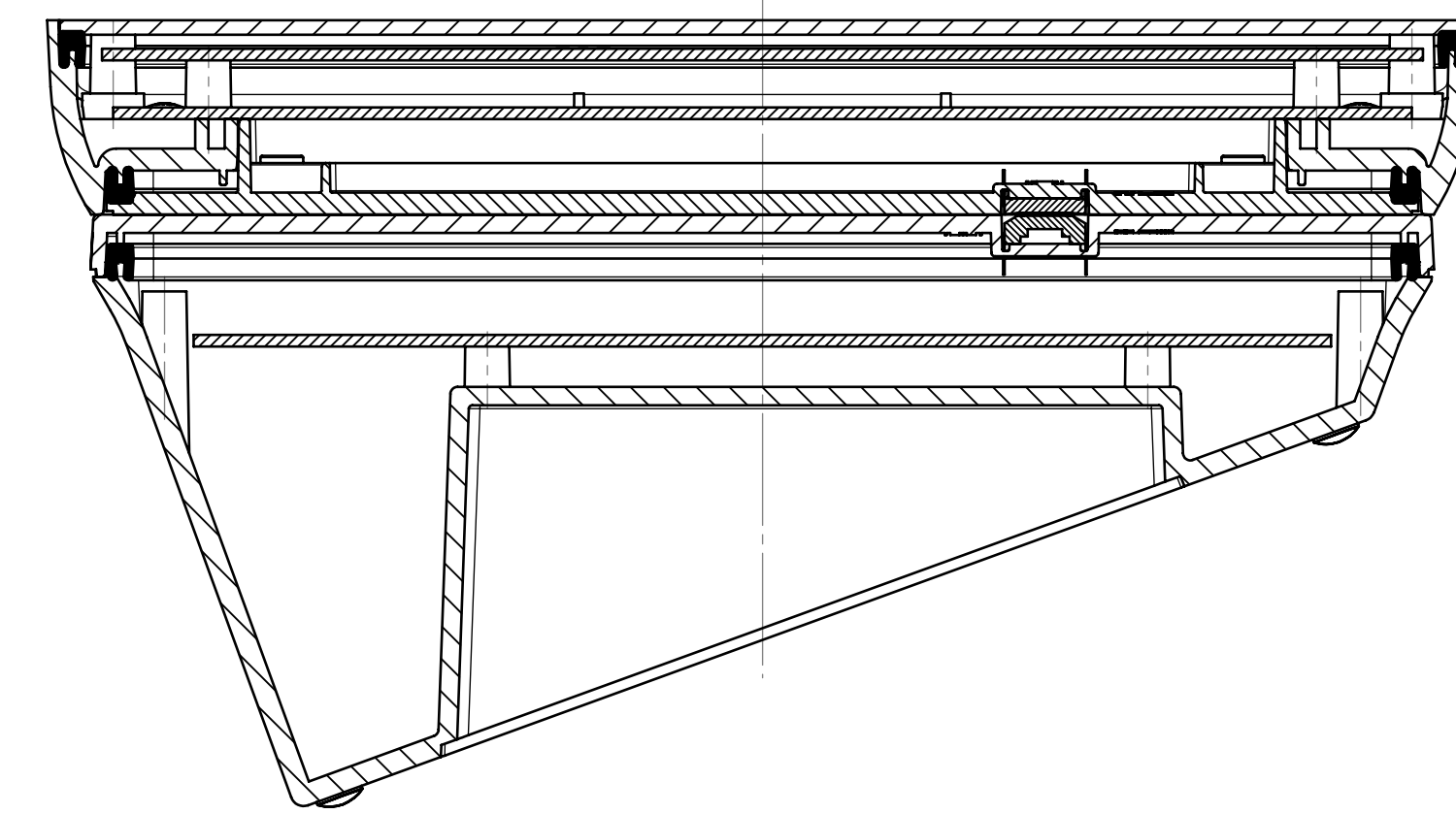

Folientastatur  
Membrane keyboard

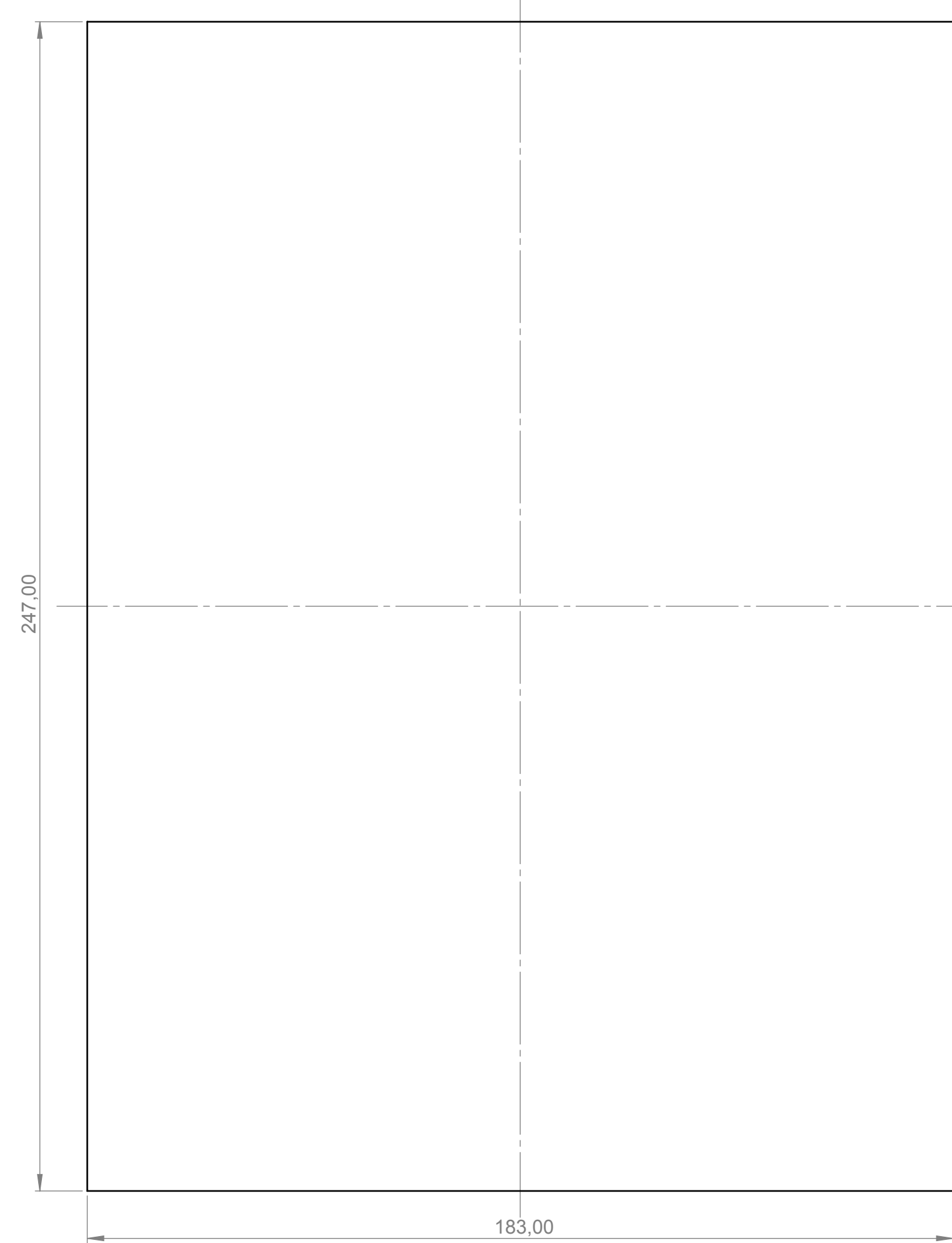

Platine Oberteil  
PCB cover

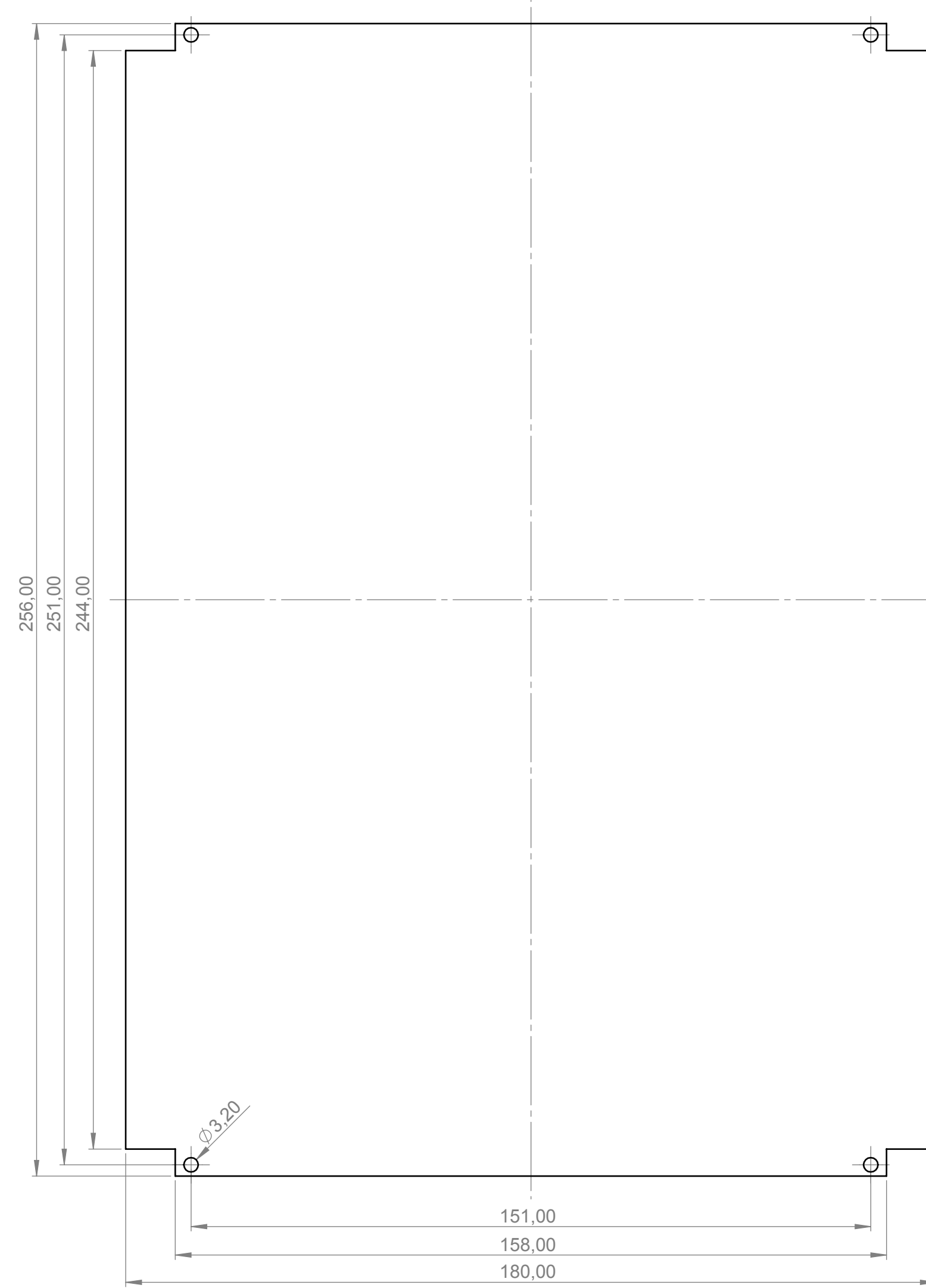

Platine Unterteil  
PCB bottom part

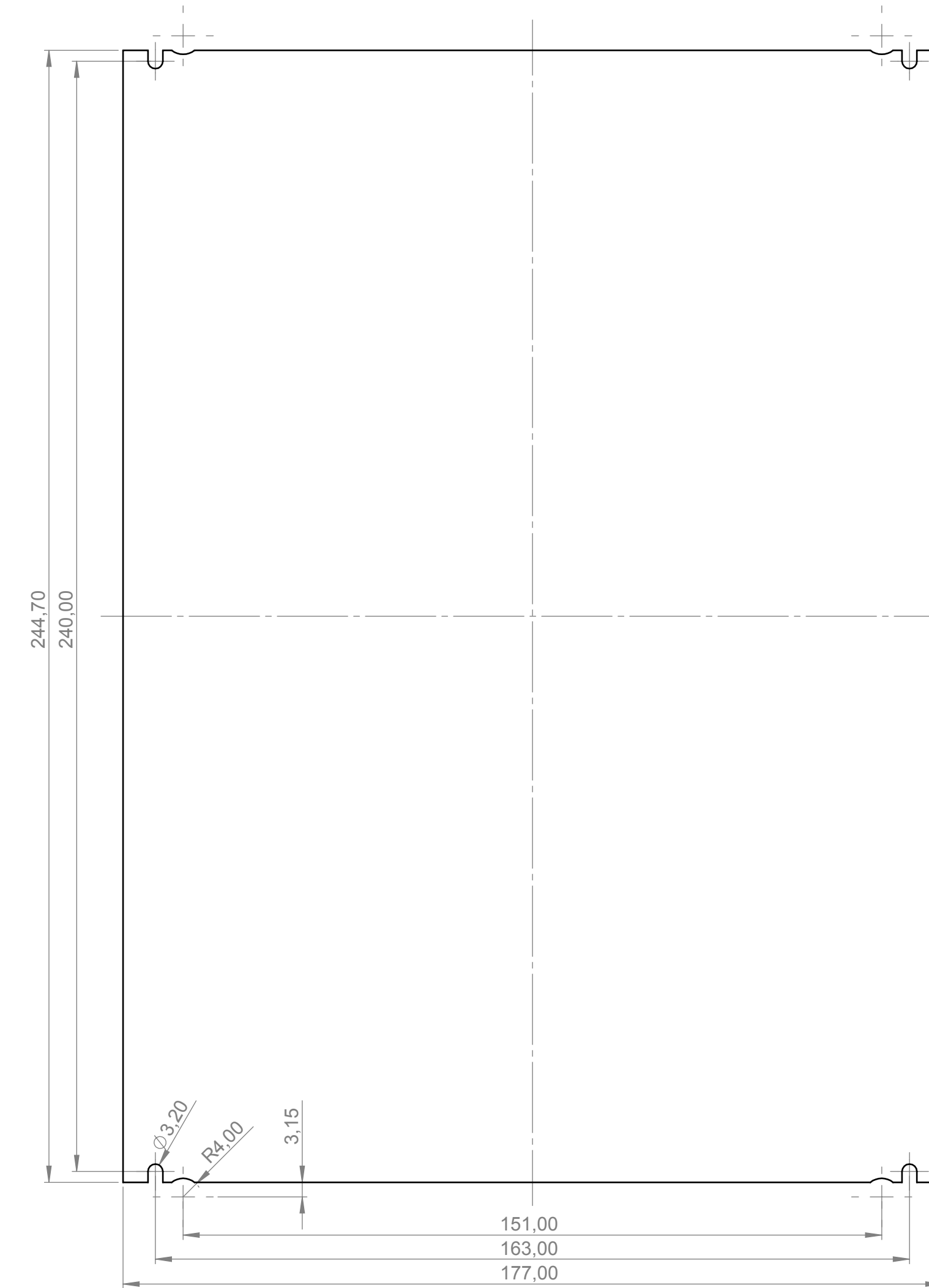

Platine Unterteil mit Batteriefach  
PCB bottom part with battery compartment

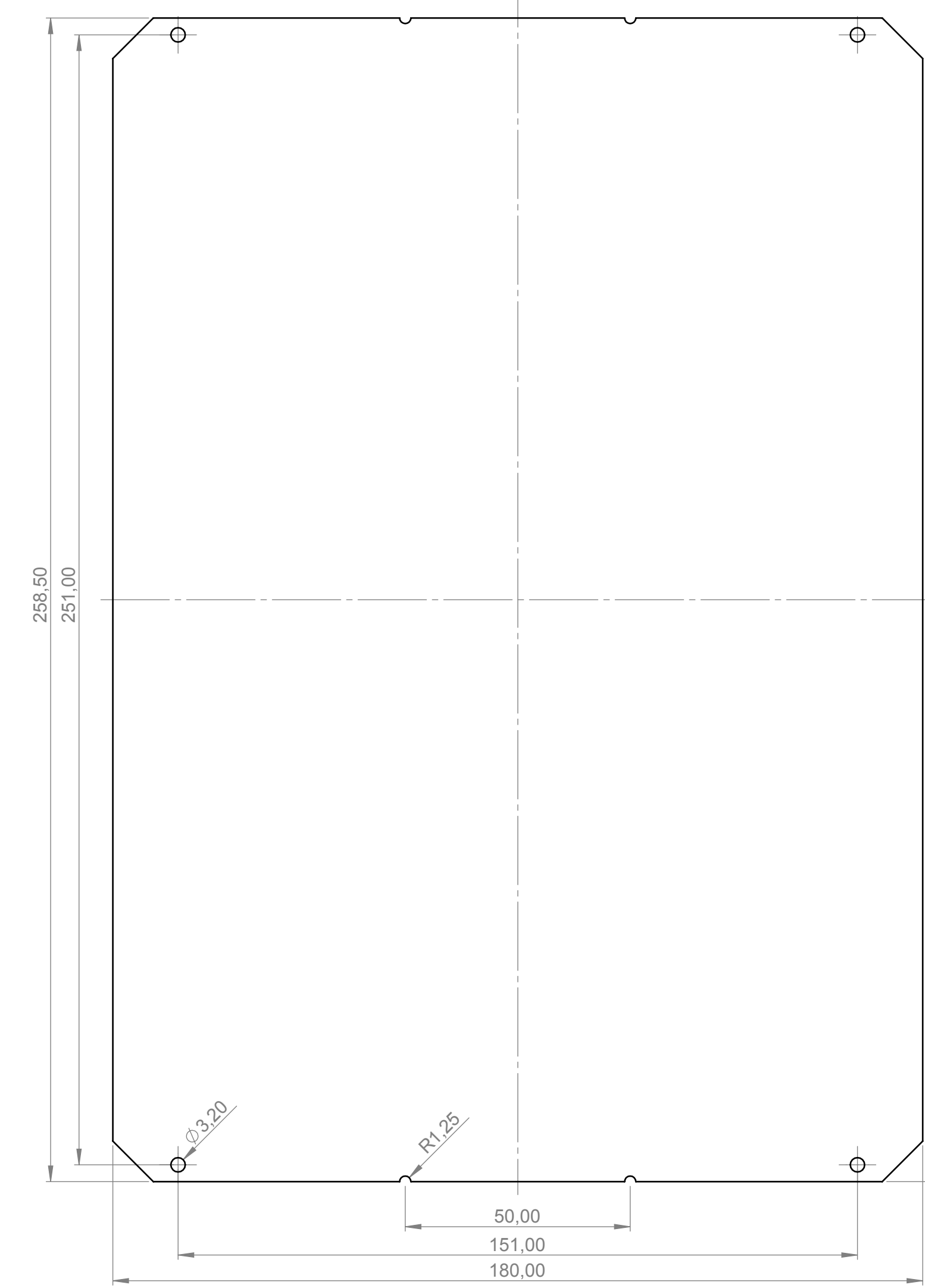

Platine Sockel  
PCB base

