

Platine fürs flache Oberteil
PCB for the flat top

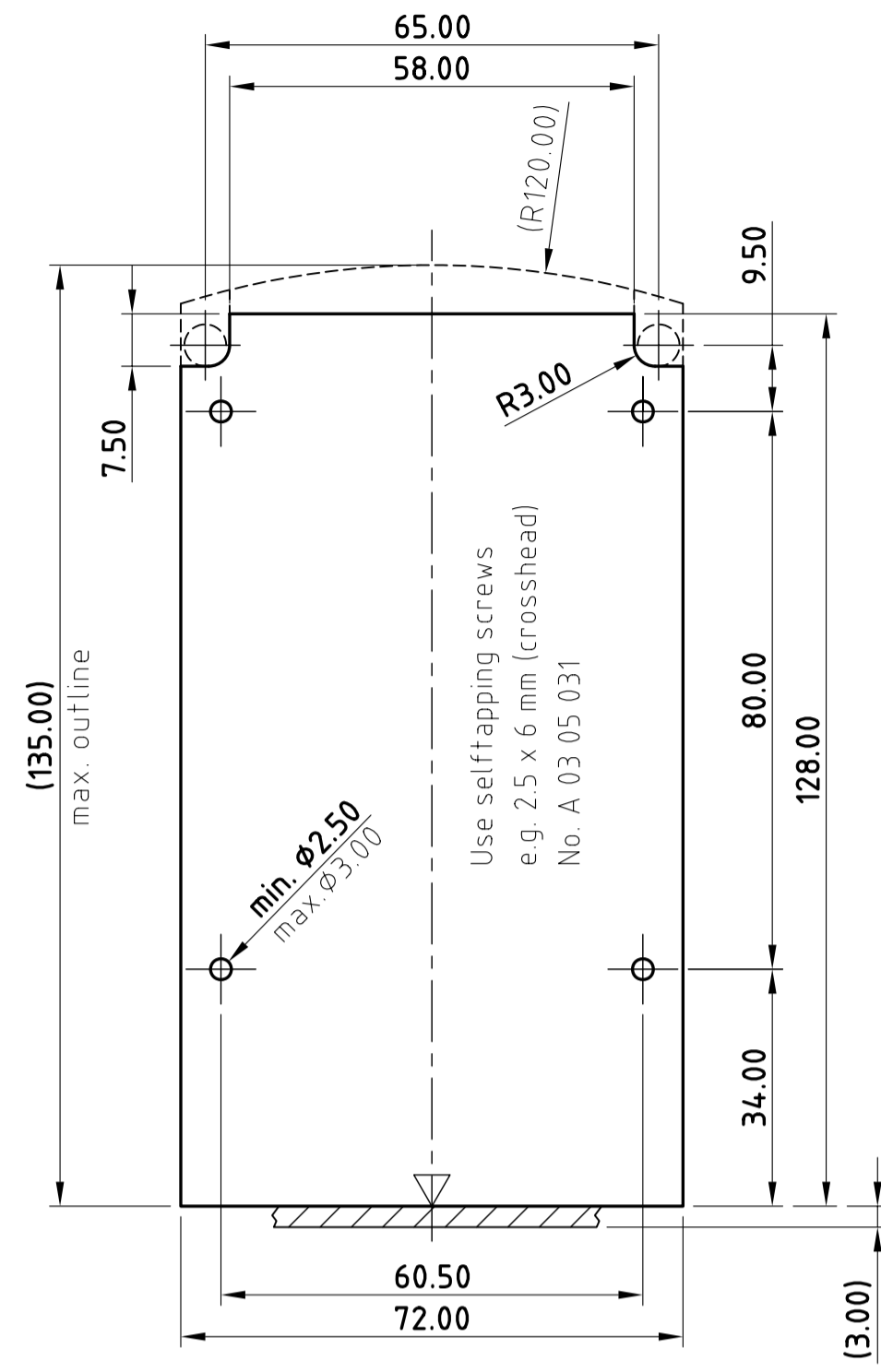

Schnitt C-C section

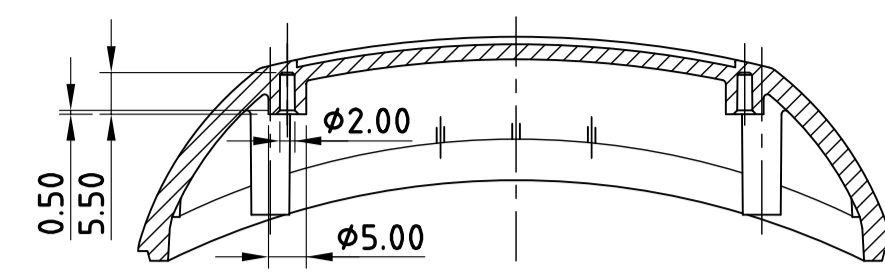

Schnitt A-A section

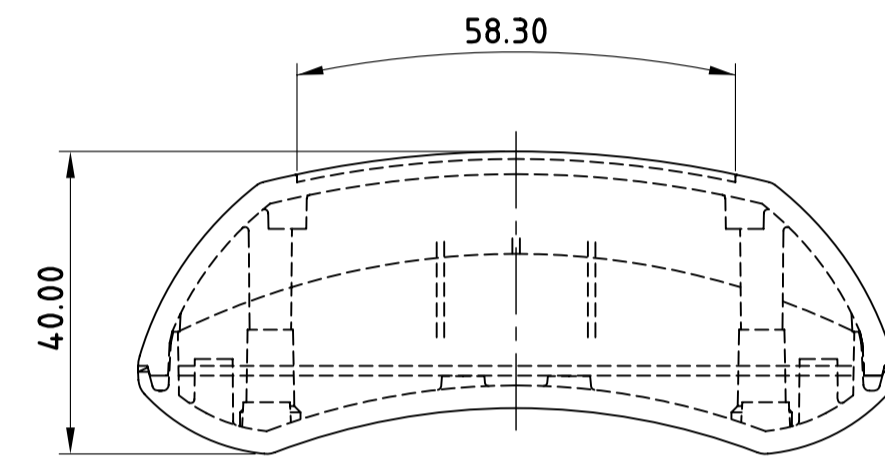
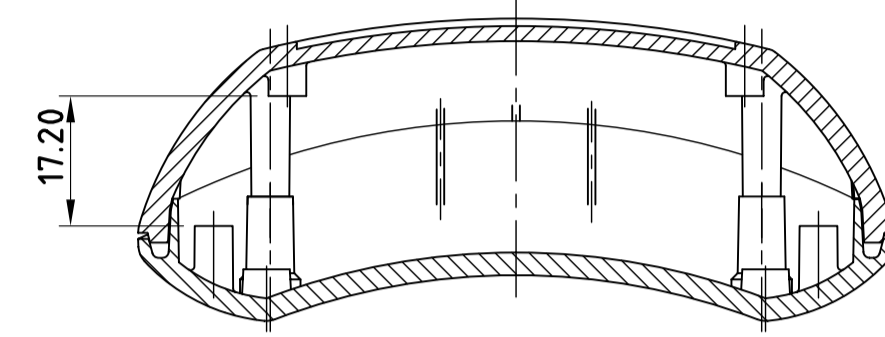

Schnitt C-C section

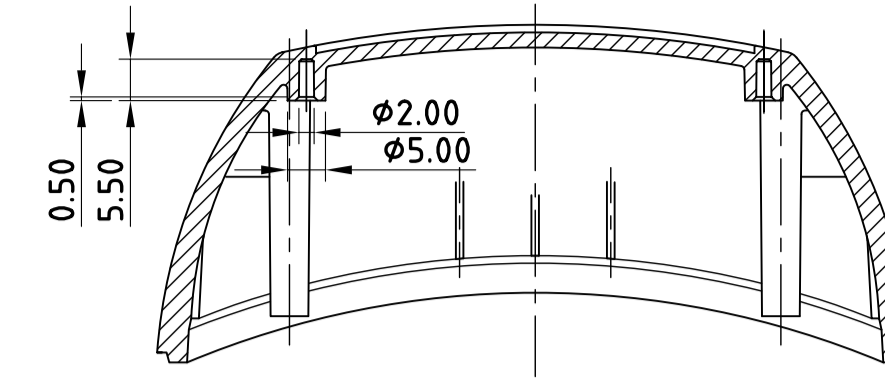

Schnitt A-A section

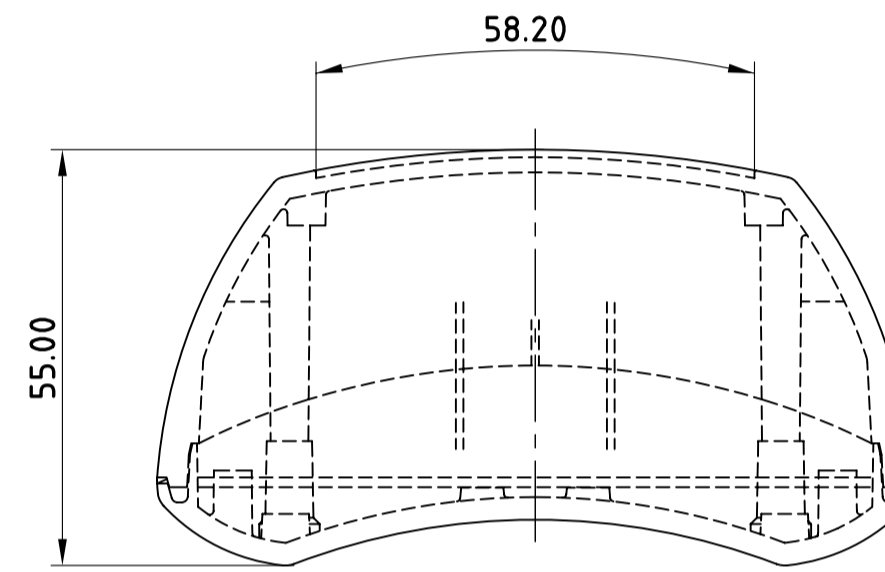
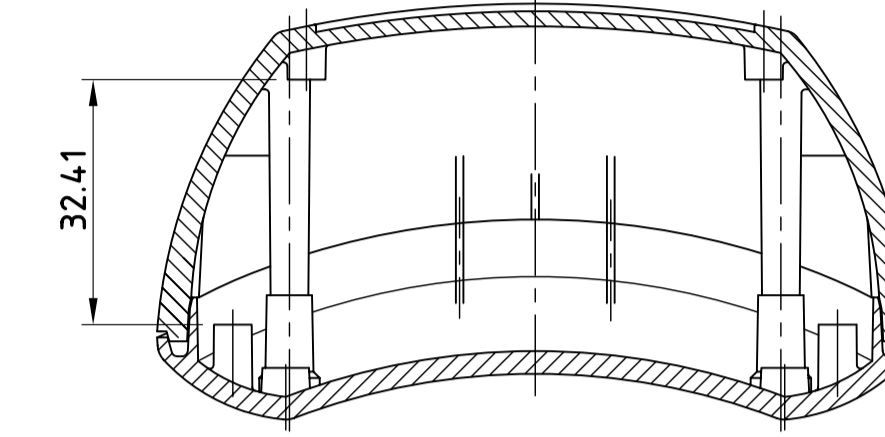

Platine fürs hohe Oberteil
PCB for the high top

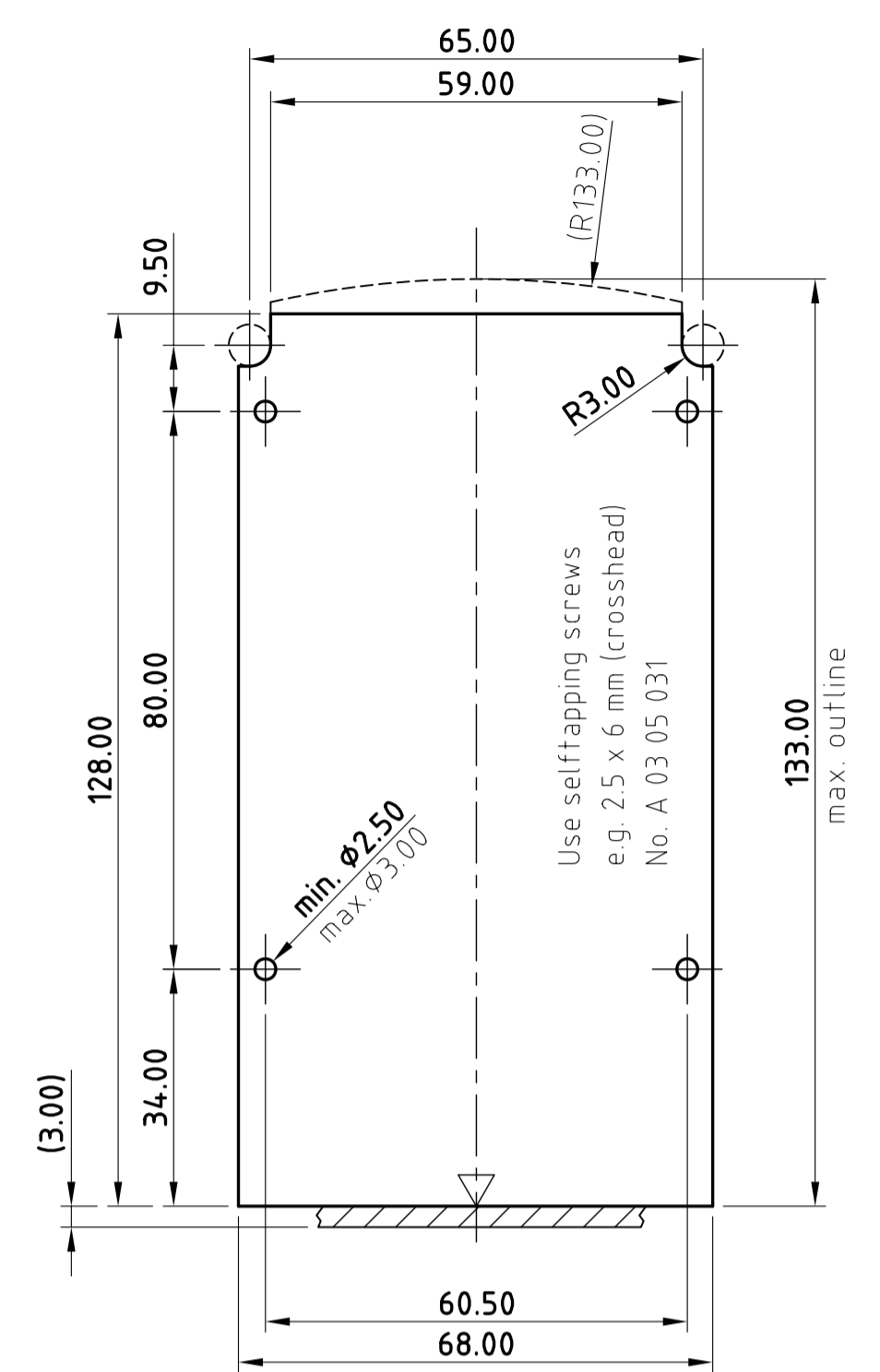

Schnitt B-B section

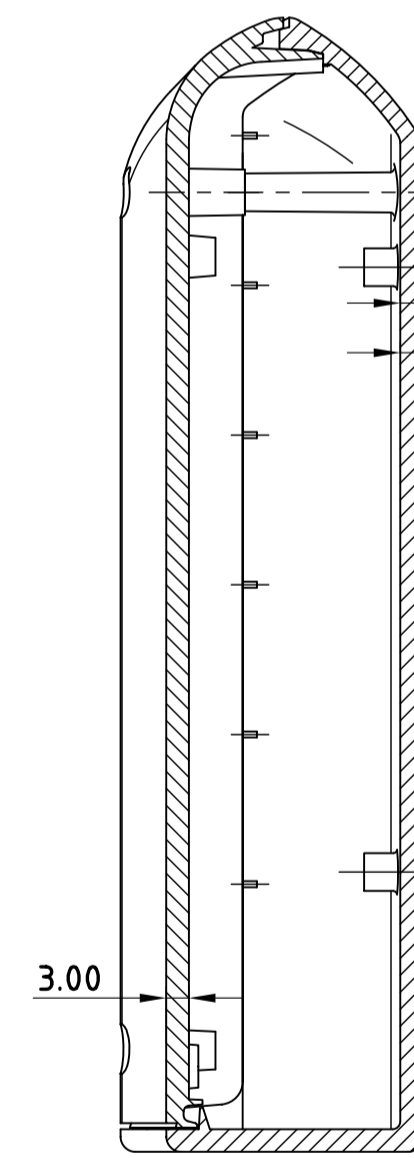

Schnitt B-B section

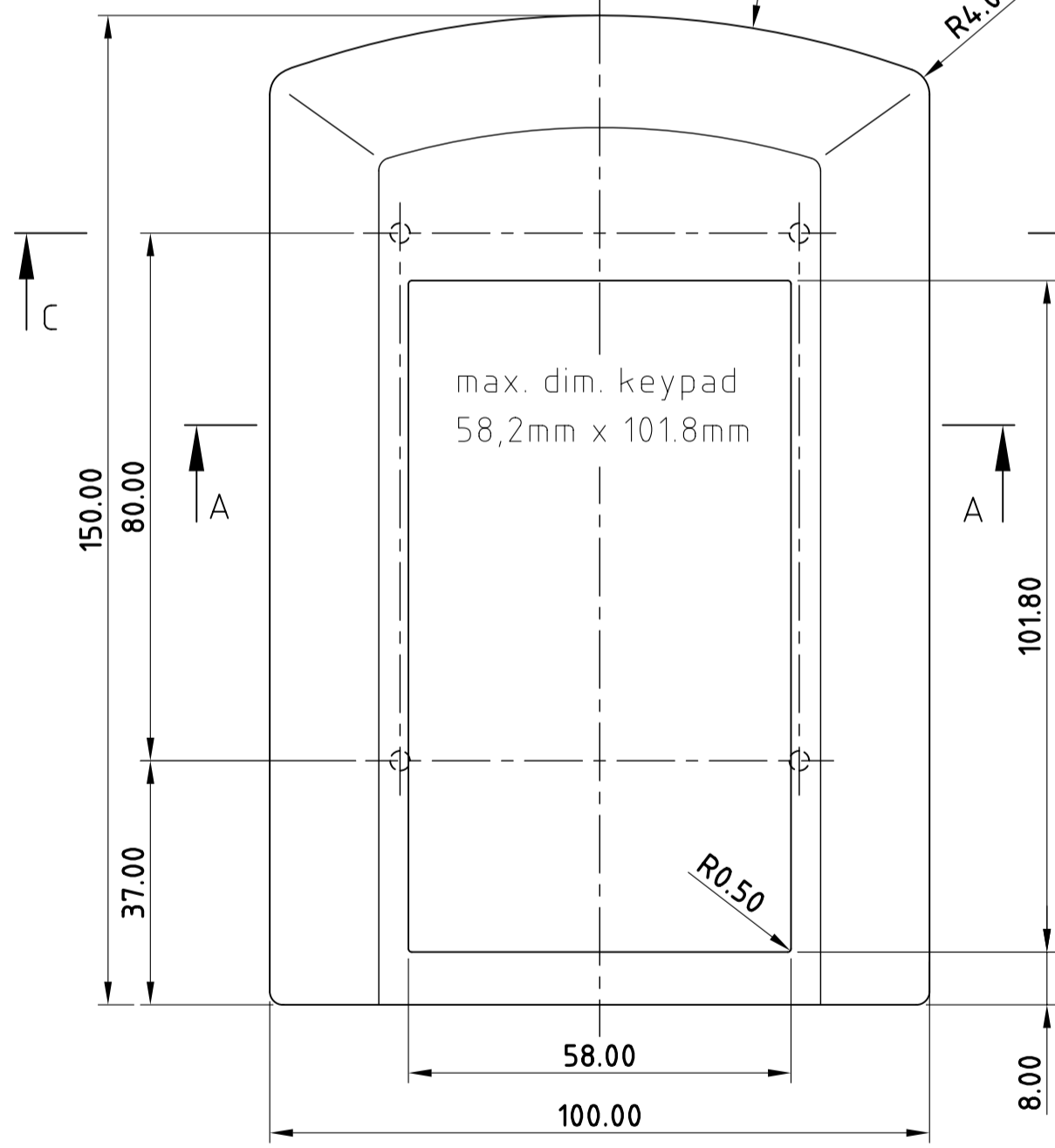

Schnitt B-B section

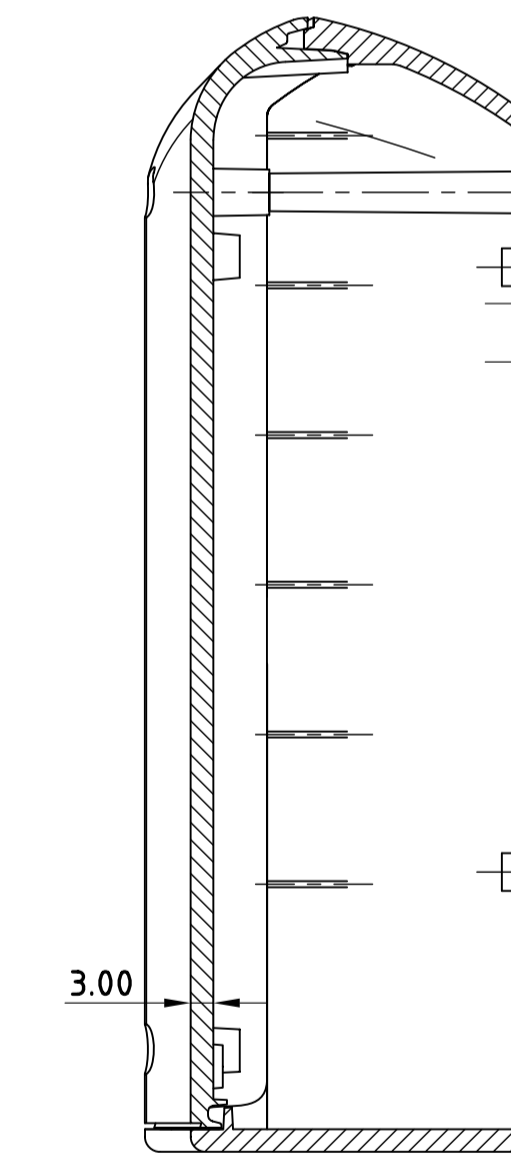

Schnitt B-B section

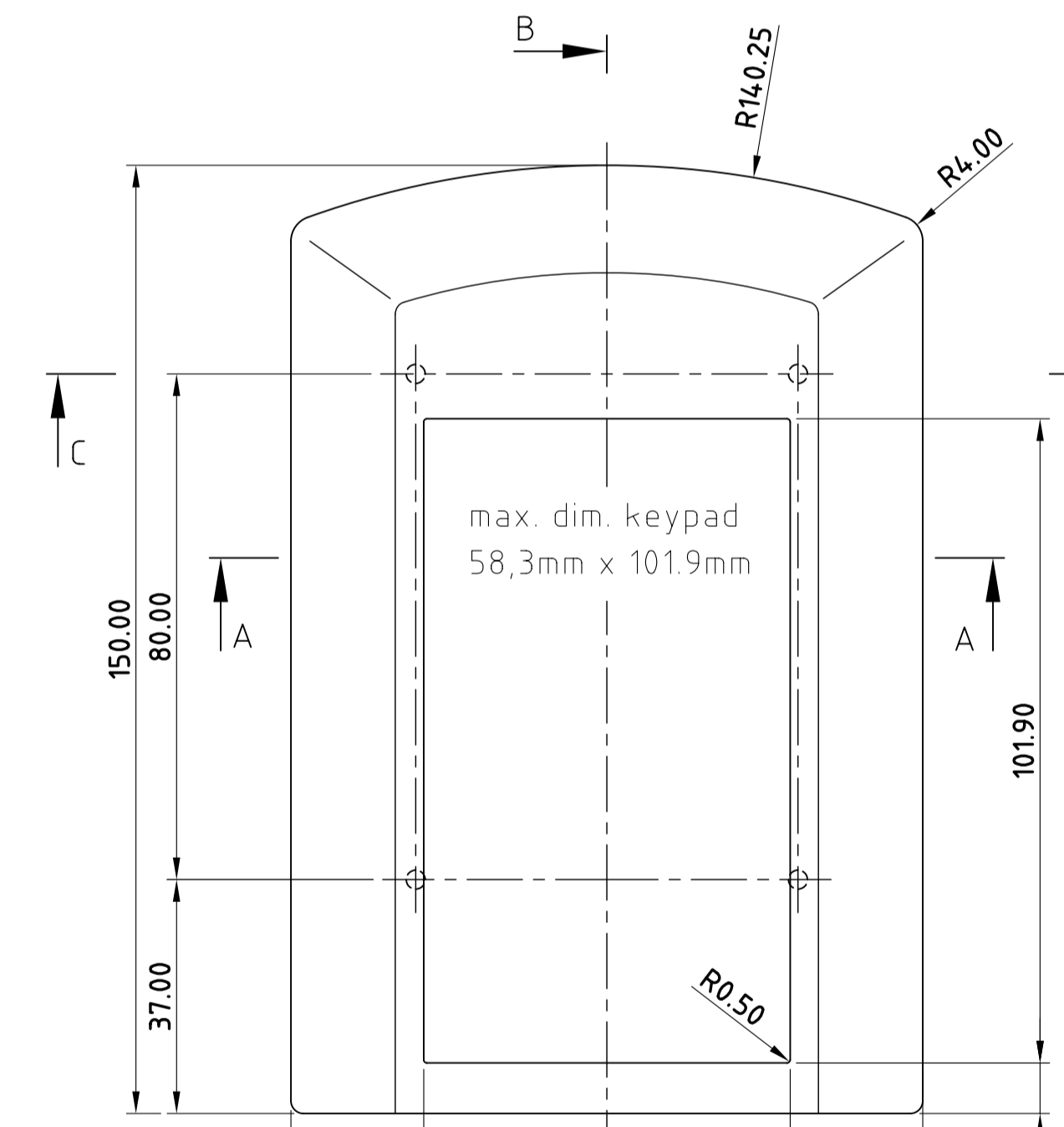
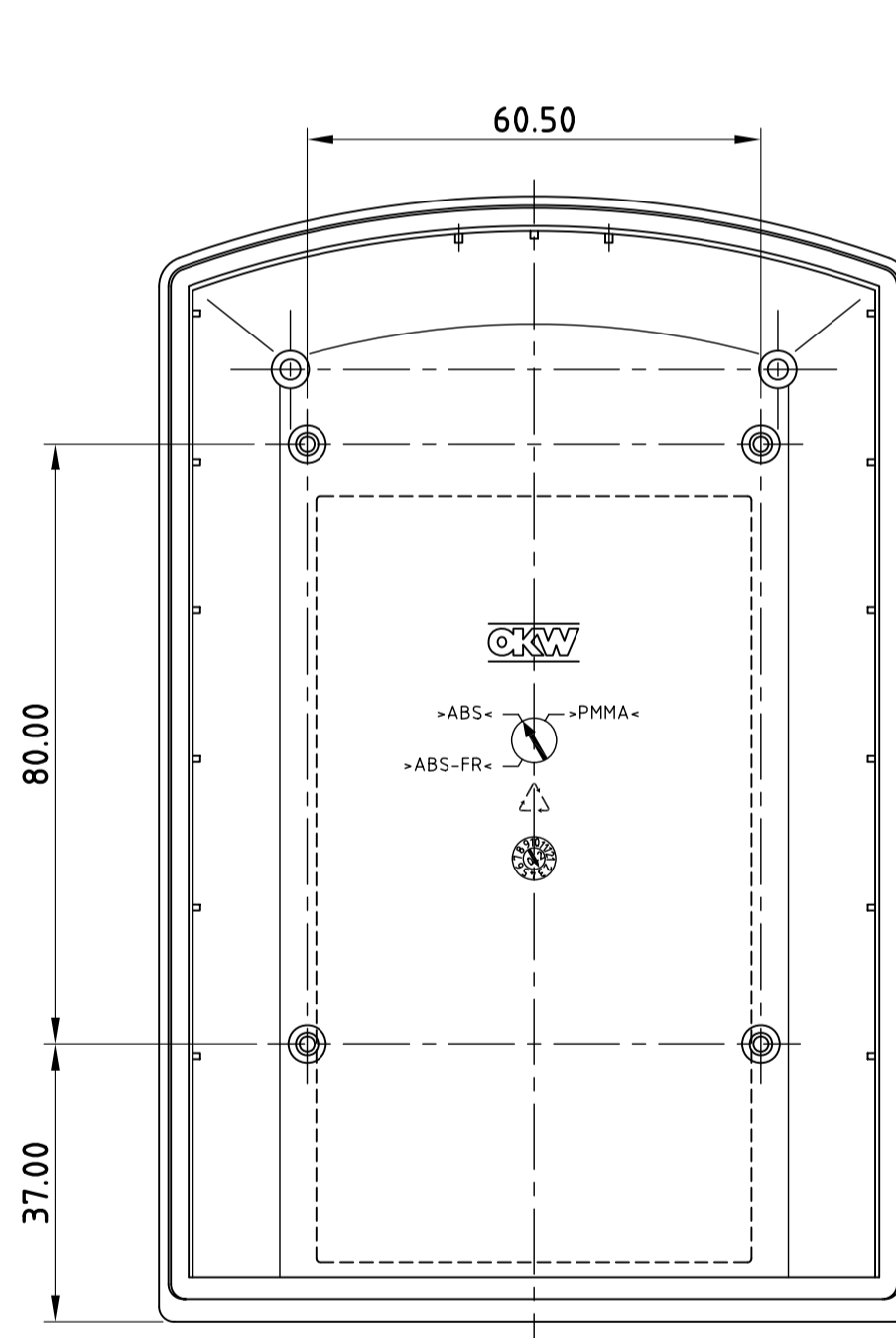
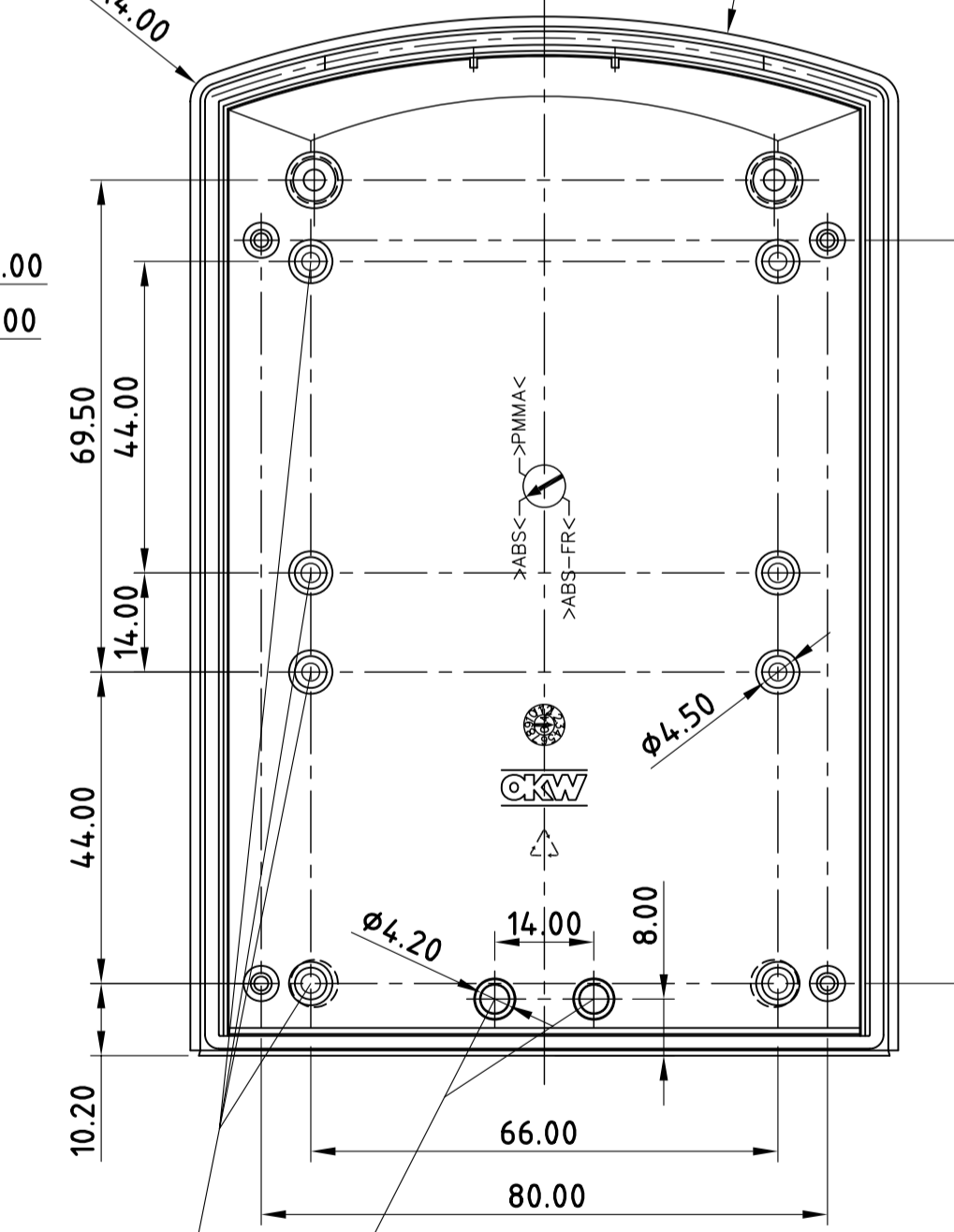

Informationskopie wird nicht aktualisiert	Copy for information will not be updated	Bearb. am: 09.07.04 Ersteller: Herrlich Freigabe: 3 Rev. Index: 3 Stand: 11.07.06	Material: Farbe: Zeichnungsart: KUNDE	Toleranz: DIN 18011 T130	DIN 6 Teil 2 Maßstab: 1:1
Technische Änderungen vorbehalten. Irrtümer und Druckfehler begründen keinen Anspruch auf Schadensersatz. Wichtige Einbaumaße bitte direkt mit dem aktuellen Produkt abstimmen. Subject to technical modification without prior notice. Typographical and other errors do not justify any claim for damages. All dimensions should be verified using an actual modified part. Sous réserve de modifications techniques. Toute erreur ou faute d'impression ne justifie aucune demande d'indemnisation. Nous priions les clients de vérifier les dimensions des composants avec les boîtiers avant le montage.		OKW GEHÄUSE SYSTEME		ERGO-CASE M ohne Batteriefach F/H B701.2..	
Für dieses Dokument behalten wir uns alle Urheberrechte vor. Es darf auch auszugsweise weder ververviältigt noch Dritten in irgendeiner Form zugänglich gemacht werden.		Bearbeiter: Hasselb. Dateiname: 00006701			