

### **Wire-Wrap Wrapping Technique**

#### **Wire-Wrapping Tools**

- Electric Powered Tools
- Battery Powered Tools
- Air Powered Tools
- Hand Squeeze Tools
- Manual Tools
- Manual strapping Tools

#### **Wrapping Bits Stationary Sleeves**

- Extension Adapter Assembly
- Technical Datas
- Survey
- Survey DIN EN 60352-1
- C.S.W.
- Siemens Type
- Secondary Bound Connections

#### **Unwrapping Tools**

- Battery Tools
- Manual Tools
- Replacement Stripping Blades

#### **Micro-Wire-Wrap Tools**

#### **Cutting and Stripping Tools**

#### **Accessories**

#### **Exploded Drawings**

**Click**  
ON THE  
SECTION  
YOU WANT

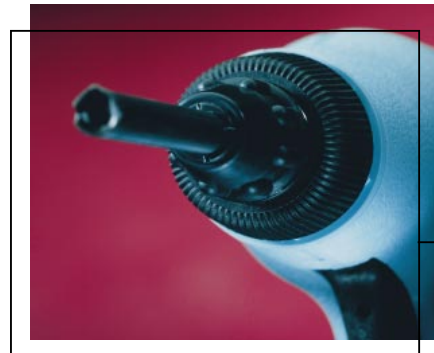

**Wire-Wrap®**

**Wire-Wrapping Tools**

### The Wire-Wrap Wrapping Technique

The Wire-Wrap system limits the electrical connections to the two absolutely necessary mechanical elements, the wire and the terminal.

The slim wire wrapping tool (consisting of the tool, bit and sleeve) wraps the solid round copper wire under mechanical tension with several turns tightly around the edged terminal. On the edges of the terminal we get a corrosion-safe and gastight connection.

In general wires of 0,25 mm - 1,0 mm diameter (AWG 30 - AWG 18) are connected with hand-held tools. There are three different sorts of wrapping bits: Modified, Standard, and CSW-Bits (see page 228).

A solid, round wire is used for „Wire-Wrap“ connections. Because of the mechanical tension which appears during the wrapping process the wire material must have a high enough elongation at the breaking point. That means, for a wire diameter up to 0,5 mm (AWG 24), the minimum elongation at breaking point must be 15%. If the wire diameter is larger than 0,5 mm the elongation at breaking point should be 20% minimum. The wire material for CSW bits must also have a minimum elongation of 20%. Please note the additional information on page 244.

Customary copper wire, f.i. conductor copper E-CU58F21 according to DIN 40500 page X or „OFHC copper“, can be used for this wrapping system. the mostly used insulation materials are: PVC, Kynar, Milene, Teflon and Tefzel. For the CSW-Wire-Wrap-Technique the wire should have a plastic insulation material which can be notched and torn off with rectilinear knife blades. The insulation itself must have a low bond strength between the wire and the insulation and should not exceed the slip-off values according to the table on page 243. Also the extensibility of the insulation must be large enough to avoid any scratches on the insulation of the lowest insulated turn of the modified connection.

In most cases the terminal sizes are known through the components used (connectors, sockets, switches etc.)

On pages 241- 243 of the catalogue you will find a selection of bits and sleeves with a classification of the wire diameter which can be used for connecting the standard terminals according to DIN EN 60 352 - 1. To adapt the bit to the wrapping terminal the actual diagonal must be known. This results from the arithmetical diagonal, the manufacturing tolerances, the corner radius and corner burs of the terminal. The number of turns with the blank wire are selected so that the sum of the single contact zones are larger than the cross section area of the line copper. The best hardness range for the finished wrapping terminal is between HV5 = 150-220 kp/mm<sup>2</sup> Vickers hardness.

The Wire-Wrap connections are made with a tool, largely eliminating human influence. Frictional forces on the wrapping radius of the bit are wearing and damaging its surface. After many thousands of connections the wrapping radius will become larger and the connections will become less tight. Eventually jagged points or pits may appear on the surface of the wrapping edge. In this case the wrapping tension might be increased to the point of creating brittle connections.

A periodic verification of several connections ensures constant quality. The check consists of two simple tests: the „strip force test“ and the „unwrap test“. For the strip force test the terminals must be tightly clamped. the stripping tool consists of a gauge provided with a dial showing the force by which the connection is stripped off from the terminal.

The jaws of the stripping tool hook should be plane, creating a flat surface contact with the wire on either side of the terminal at the lead end of the connection. Also the jaws of the hook must engage along the major dimension (cross selection) of the terminal. the minimum clearance when the terminal and striping tool are properly aligned must be such that there is no binding between jaw and terminal. The stripping force shall be applied slowly and steadily so that any inertial removal force shall be negligible. The maximum rate of stripping should be 250 mm per minute. The connection on square terminals must reach or exceed the minimum strip force before

the wrap starts to move on the terminal. No maximum value is defined for the strip force (please see page 258).

Brittleness of the wire can be checked through the „Unwrap test“. Purpose of the unwrap test is to check whether the wires have been elongated too much during the wrapping process. this test is made with an unwrapping tool which is placed over the terminal and being rotated contrary to the wrapping direction (hand-held wrapping tools normally wrap the wire clockwise). The wire is unwrapped and kept on the tool. During the unwrapping process the wire must not break within the connection area and needs not to be straightened.

It is recommended to record the results of the strip-force test and unwrapping test on a test sheet (see page 258). A comparison of the strip force totals shows the condition of the bit. Decreasing strip force indicates a wear of the bit radius. Increasing strip force indicates damages of the bit radius that can lead to brittleness of the wrapped wire.

**Important: The „strip force test“ and the „unwrapping test“ must be made once a day!**

When visually inspecting the wrap connections make sure that there is no wiring mistake as described on page 229.

**Wire-Wrap® is the original wire-wrapping tool developed in the late 1950's and is registered trade mark of Cooper Industries, Inc.**

## Wrapping Technique

### Principle and reliability of the Wire-Wrap connection

A permanent reliable electrical connection is obtained when a round solid conductor is wrapped around a sharp edged terminal by means of a wrapping bit. The wire and the terminals have to meet the specifications DIN EN 60 352-1, etc. ..., i.e. the usual quality available on the market.

### Intimate contact of bare wire and terminal corners

During the wrapping process, the wire is pulled from the wire slot by the rotation of the bit around the terminal. The wire is drawn over the wrap radius that intersects the bit face and the wire slot, placing tension on the wire in the process. This tension causes stretch of the wire.

As the wire is wrapped under mechanical tension, the sharp corners of the terminal penetrate into the surface of the wire and an intimate and large surface of contact is established.

As the turns of wire are hooked at each corner of the terminal, the mechanical tension produced by the wrapping bit remains stored in the wrapped wire and a permanent gas-tight connection is established. After the wrapping operation, the terminal that has been twisted in the direction of wrapping will slightly untwist and some relaxation will occur in the wire material. After some hours, when the connection is stabilized, the compression between wire and terminal corners is from 50.000 psi (35Kg/mm<sup>2</sup>) to 100.000 psi (70Kg/mm<sup>2</sup>), depending on the wire diameter and on the wire material. Four turns of wire, i.e. 16 contact points provide a surface of contact equivalent to the cross section of the wire.

The electrical resistance of a wire wrapped connection is in the range of 1 milli ohm, which is less than electrical resistance of one inch of length of the wire used to establish the connection. When the connection ages solid state diffusion at the interface corners and wire will often increase the conductivity of the connection.

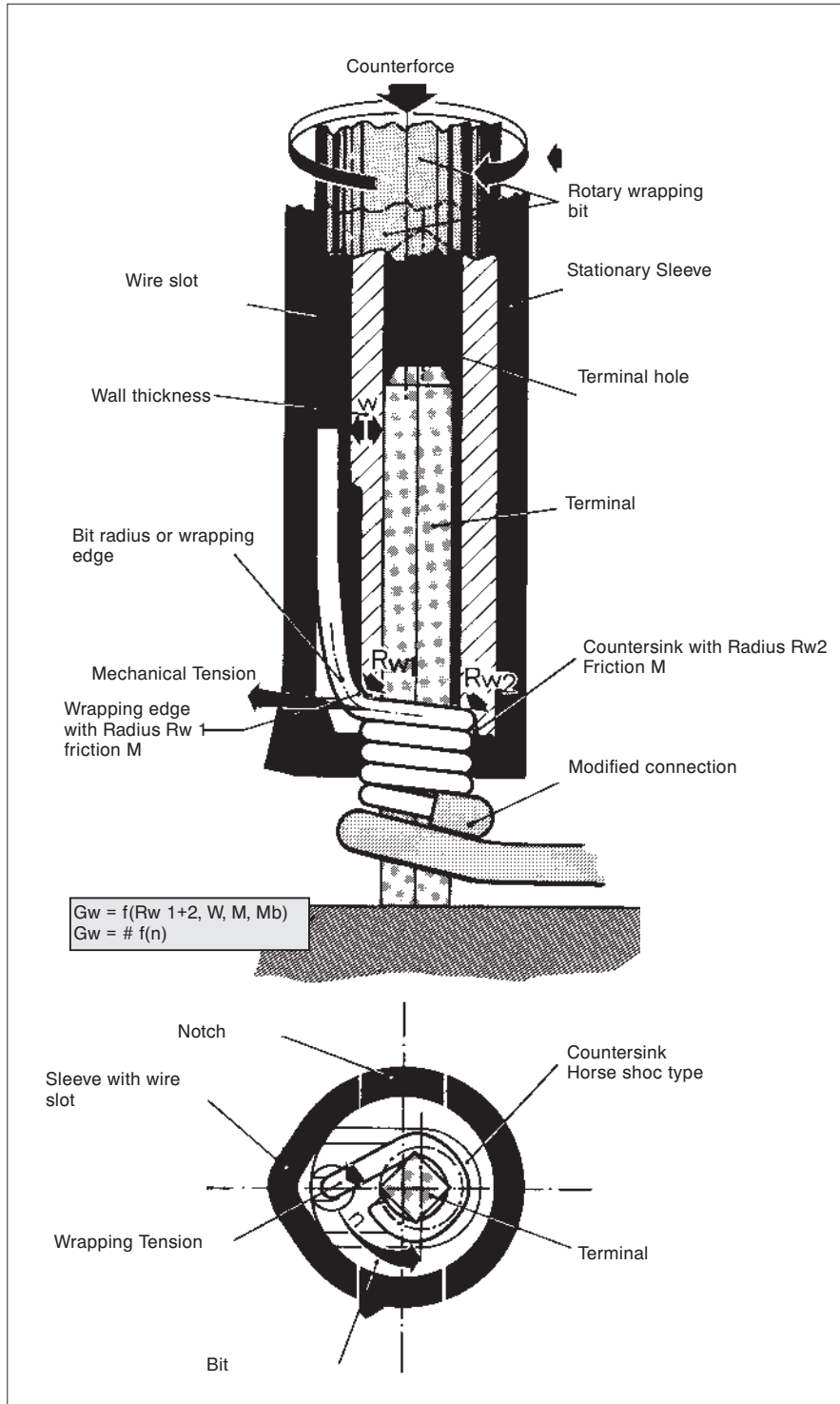

ø of Bare Wire mm	AWG	Wrapping Force	
		kp	ca. N
0,25	30	1	10
0,32	28	1,6	16
0,4	26	2,5	25
0,5	24	4,1	41
0,65	22	6,5	65
0,8	20	10,4	104
1,0	18	15,8	158

### Wire-Wrap Wrapped Connections



Depending on the bit style, the wire is either stripped during the wrapping process or before the wrapping process, by means of a stripping tool or machine, to give the correct strip length.

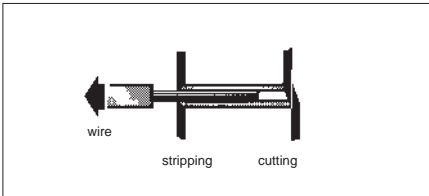

1. Cut and strip the wire

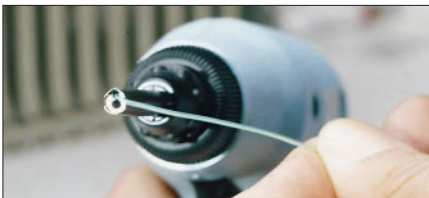

2. Insert the wire in the wire slot.

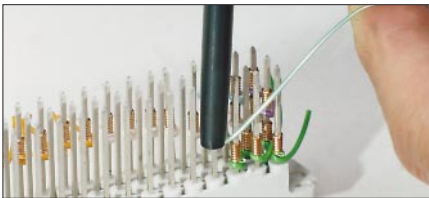

3. Position the terminal hole of the wrapping bit over the terminal to be wrapped.

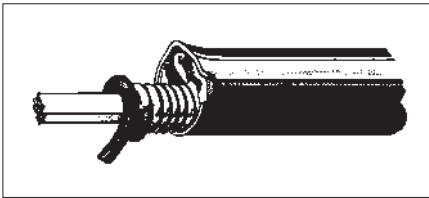

4. Wrap

### There are three different sorts of wrapping bits:

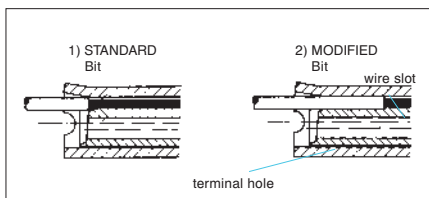

With modified or standard bits the wire insulation has to be stripped before wrapping.

As the wire formed into the sleeve notch is still held by the operator it cannot drop out of the wire slot whilst the loaded tool is located over the selected terminal.

With the C.S.W. bit the wire is cut to length and stripped during the wrapping operation.

- During the wrapping operation gently press the tool forward.
- The turns of the connection have to be nicely wrapped each against the other.
- Do not push too hard.
- Do not pull backwards.

With modified and standard bits insert the wire in the wire slot as deep as possible. With C.S.W. bits the wire has to be inserted all the way through the wire slot until it goes out of the cutting window.

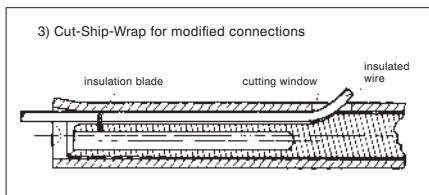

The simplified sleeve of the manual tool has no notch. The wire is held by hand.

## Wire-Wrap Wrapping Process

### Reliable MODIFIED connection

The insulation of a connection made on the second level may overlap the last turn of the connection wrapped on level one. The MODIFIED wrapping bit will wrap one turn of insulation at the base of the connection.

### Reliable STANDARD connection (not modified)

The standard wrapping bit wraps only the stripped part of the wire on the terminal.

## Correct MODIFIED connection

## Correct STANDARD connection

Numbers of turn of conductor	related to conductor diameter	
	{mm} d1	(AWG)*
8	0,25	(30)*
7	0,32	(28)*
6	0,4	(26)*
5	0,5	(24)*
4	0,65	(22)*
4	0,8	(20)*
4	1,2	(18)*

\*AWG = American Wire Gauge is internationally accepted for conductor diameter definition.

## The golden rules of wire wrapping

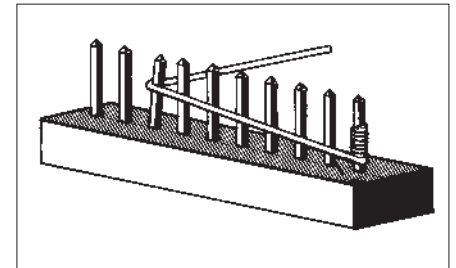
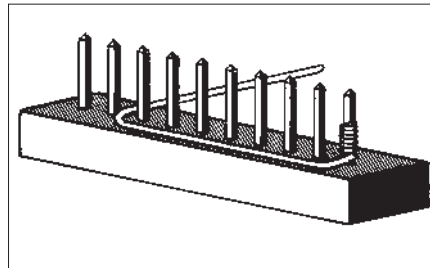
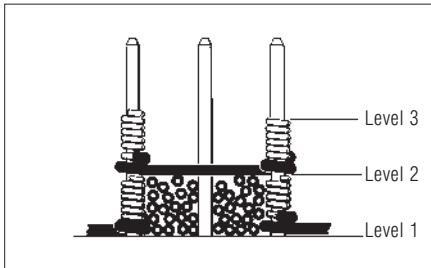

Correct dressing of the wire around a terminal

Incorrect dressing of the wire. No clearance between wire and terminal.

1. Only two connections on the same terminal (Level 3 is kept as a reserve for change and repair)
2. Wrap both ends of a wire on the same level.
3. Wrap long wires first.
4. Removal of connections: simply unwrap and do not re-use the unwrapped wire

## Wrong

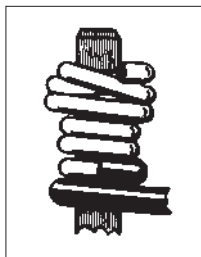

**Overwrap:**  
too much backforce or improperly selected bit

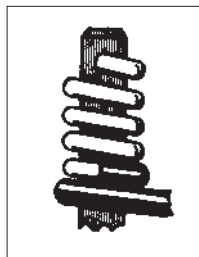

**Spiraled connection:**  
the tool has been pulled backwards during the wrapping process



**Too much „Pig Tail“:**  
the last turn of connection is not formed against the terminal  
damaged wrapping bit  
ratio between terminal width and thickness too large

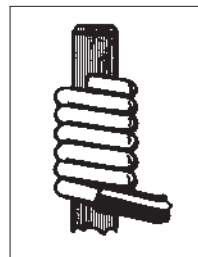

**Insufficient insulation for a MODIFIED connection:**  
the wire has not been inserted deep enough in the wire slot, or has slipped out just before wrapping



### Is contact pressure high when the conductor is wrapped around the corners of a wrap termination post under mechanical tension?

Contact resistance is composed of the sum of the input resistance and the surface contamination resistance. A small contact resistance is reached through reduction of the input resistance by means of high contact pressures by many, large-surface contact zones and the surface contamination resistance by metallicly blank contact zones.

The wrap post is usually rectangular or quadratic. It must have well formed corners - if the conductor is wrapped around a round termination post under mechanical tension, it will release itself as soon as the wrapping process is completed and the high contact pressure between the termination post and the wire will no longer exist.

The contact surface will therefore remain very small and not metallicly clean. This type of connection must also be soldered after wrapping if it is to permanent or if the electrical conductivity should be increased.

When the conductor is wrapped around the angled post with high tensile stress, the edges of the wrap post press into the soft copper wire. The tensile stress causes the conductor to stretch elastically and plastically and can then be pulled around the edges of the wrap post.

This causes any oxidised layers on the surface - of the conductor as well as the edges of the post - to rupture. These layers are then scraped off and pushed through during the impression of the wrap post edges. A new oxide layer cannot occur during the brief wrapping period since the process takes place at room temperature. Fluxing agent is also not required for this reason.

In this way large-surface, tightly joined, airtight, metallicly blank contact zones develop high pressure.

A wrapped wire connection consists of a large number of these contact zones, which results in a very low resistance due to the parallel connection.

A four-corner wrap post and 5 windings of the blank conductor results in 20 paralleled contact zones. This means that the entire contact surface is greater than the cross-section of the wire.

Each individual conductor section (area of winding between two wrap post edges) presses against the edges of the wrap post with both ends. The entire wrapping therefore functions as a wrap spring. The conductor is not overstretched during the winding process and still has extra elasticity. Even the wrap post itself is pressed together somewhat and is subject to elastic torsional stress. This ensures that sufficient elasticity is stored in the wrapping - even after a certain release of stress in the conductor after the winding process - in order to guarantee complete reliability.

Intensive ageing experiments have shown that for the required service life of 40 years, at a temperature of 57°C, the tension in the conductor declines and therefore the contact pressure decreases as well to 50% of the values which were present one week after the winding process.

The contact resistance increases only slightly since the contact surface must remain unchanged for the most part in order to maintain the low value, but not necessarily the contact pressure. If the metallic parts were tightly joined due to initial plastic deformation of the conductor, the metallicly blank contact zones (and thereby also the low input and surface contamination resistance) are retained if the contact pressure is reduced in relatively wide junctions. These investigations were confirmed by more extensive measurements made at the U.S. Naval Avionics Facility Indianapolis (NAFI) on conductors with  $\varnothing$  0.25 mm (AWG 30) and  $\varnothing$  0.4 mm (AWG 26).

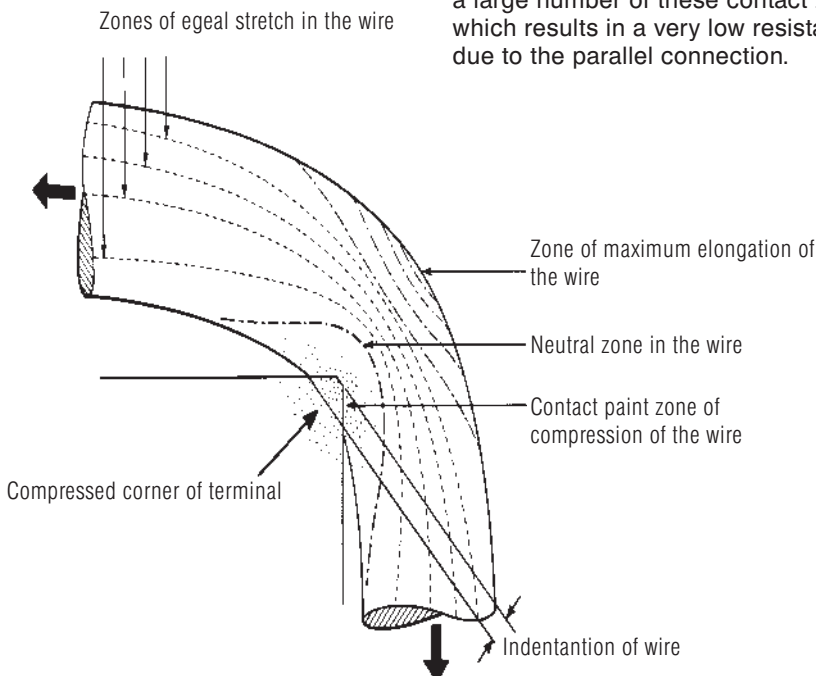

## Wire-Wrap Tools with feature perfectly adapted to the job

Before selecting and using a new tool, check

- the nose piece you need
- the position of the index system
- the service instructions

Production tools can be equipped either with an „A“ or with a „C“ nose piece. The suffix denotes the nose piece type.

Example: 14 YP1...A: solid nose piece; 14 YP1...C; nose piece with backforce.

### „A“ nose piece.

The wrapping bit is actuated by a coupling that is pressed forward via the tool itself during the wrapping process. This means that the backforce applied on the connection is the same as the force applied by the operator.

### Advantages:

- Tool is simpler
- The operator acquires quickly a good feel of the force to apply to obtain a good wrap.
- The „A“ nose piece is used universally in production.

### „C“ nose piece:

A spring is inserted between the bit coupling and the tool mechanism and handle. This means that the bit will retract in the sleeve during the wrapping process.

### Advantage:

The backforce applied on the connection is more constant and to a certain extent, independant of the force applied by the operators.

The index system will stop the bit in the same angular position after each wrapping operation: this facilitates the insertion of the next wire in the tool.

### Index adjustment simplifies wire insertion.

Tools are supplied adjusted for a 12 o'clock position of the wire slot of the wrapping bit.

The production tools of series 14YM1, 14YP1 and 14YB3 offer the possibility of an angular adjustment of the index mechanism. So, the position of the wire slot can be adjusted to suit the operator.

### Wire-Wrap Tools last for years.

They can be serviced and repaired by the customer's serviceman or by the authorized distributor.

### Spare parts:

We recommend the holding of a certain quantity of spare parts. These are available from your authorized distributor. Service instructions and a spare parts list are issued with wall the tools supplied by the distributor.

**Please make sure the service instructions and parts list are kept in the repair shop!**

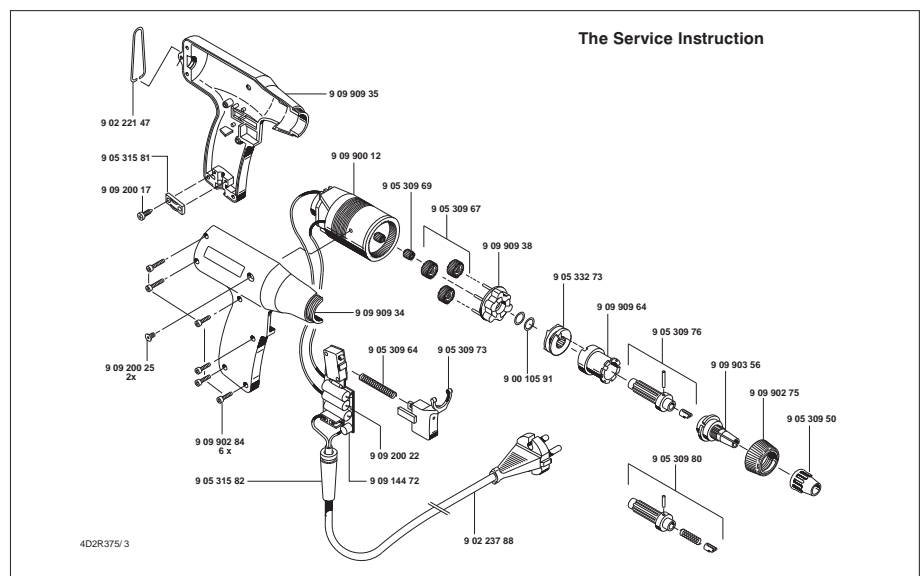
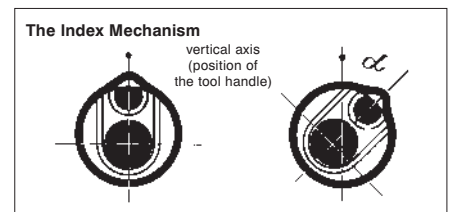
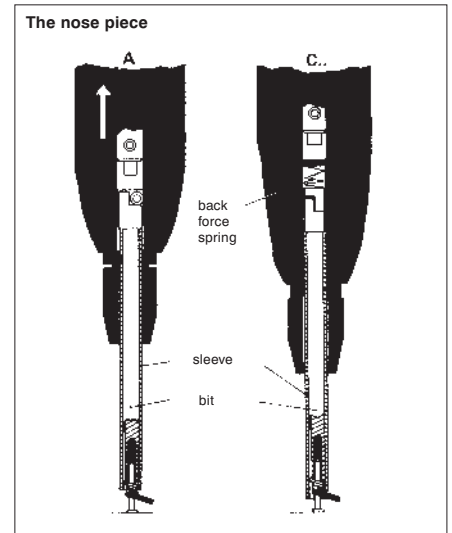

Electric powered tools are used where no compressed air is available. The rugged construction of these tools limits the service to a minimum. They meet official specifications for safety and for electrical interference protection. These tools are used for volume production, batch production and field service.

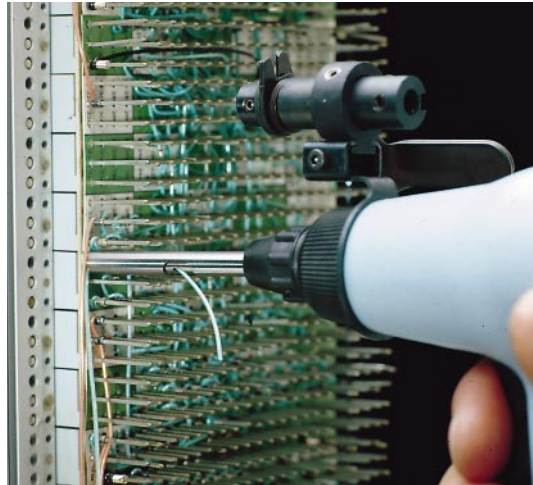

**Model 14G1**

The 14G1 - a low voltage super-light tool - specially designed for miniwrap applications.

The body of rugged plastic material.

Conductor Diameter		weight (tool only)	Designation Series	Model Number
mm	AWG	g		
0,16-0,5	34-24	250	14G1A-230	940762A5

• Power supply 230 V. Option also available for 110 Volts, 50/60 Hz.





The new tool type has been successfully tested according to the harmonized EN specs. 60395-2-45 and EN 55014. Moreover this tool meets the EG specifications 73/23 EWG, 89/336 EWG and bears the CE and CCA approval signs. Due to its refined design and construction the 14YB3 can be used on live circuitry and also on devices containing sensitive integrated circuits.



The 14YB3-230... heavy duty electrical Wire-Wrap Tool is designed for production, service and installation applications.

Its main features are:

- Powerful and reliable motor A.C.30W
- Planetary gear reduction drive
- Free rotation speed of bit 4500 rpm
- Very low noise level 70 dBA. Bears the official sign for electrical noise interference protection N-12 dB.
- Capacity: 0,20 mm to 1,00 mm i.e. from AWG 32 to AWG 18
- Insulated collet and collet nut
- Double insulated
- „Operator adjustable indexing“: eight separate positions for operator preference.
- Power supply 230 V

Conductor Diameter		with back force spring	series designation	catalog number	model number
	Weight (tool only)				
mm	AWG	g			
0,25-1,0	30-18	450	14YB3-230/A	29 315 AA3	90 29 315 3
0,25-0,6	30-22	450	✓ 14YB3-230/C	29 217 AA8	90 29 317 8
0,25-1,0	30-18	400	14YB3-120/A	29 318 AA1	90 29 318 1
0,25-0,6	30-22	400	✓ 14YB3-120/C	29 919 AA2	90 29 319 2
0,25-1,0	30-18	400	14YB2-42/A	27 252 AC9	90 27 252 9

• Tools feature 230 V or 120 V or 42/48 or 50/60 Hz



Independent of external source



### 14R3 Series

The 14R3 battery tool is designed for field repair, service, laboratory applications, and low production. Ideal for research and pre-series. The 14R3 has a rechargeable Nickel-Cadmium battery in the handle. The rotation of the tool is reverse by changing the position of the handle in the tool head. The 14R3 can be used for wrapping and unwrapping.

Charger has a recharging indicator light. Fast charge: 1 hour. A full charge permits the wrapping of 1000 connections or more, depending on the wire diameter.

In case of necessity, possibility to use dry battery. A safety feature prevents accidental charging of dry batteries. The Ni-Cd battery cell in the handle can be easily replaced. Index position can easily be adjusted on 360°.

Conductor Diameter		weight (tool only)	with Back force spring for thin Conductor-ø	series Designation	Model Number
mm	AWG	g			
<b>Including battery charger 230 V, 50 Hz</b>					
0,20-0,65	32-22	390		14R3G	296 50AD3
0,20-0,50	32-24	390	✓	14R3G/C	296 60AD2
<b>Including battery charger 120 V, 60 Hz</b>					
0,20-0,65	32-22	390		14R3F	296 00AE6
0,20-0,50	32-24	390	✓	14R3F/C	296 10AE5
<b>Without battery charger</b>					
0,20-0,65	32-22	390		14R3FK	990 680+990 655
<b>Charger 230 V, 50 Hz</b>					520 101
<b>Charger 120 V, 60 Hz</b>					990 650
					990 859
					990 650
<b>Battery Assembly</b>					990 655
<b>Ni-Cd Battery Cell</b>					990 519

- Model numbers of tools do not include the wrapping bit and the stationary sleeve.  
For selection of wrapping bits and sleeves refer to pages 261 to 270.



Pneumatic tools are preferred for volume production. Advantages:

- **Light weight**
- **Smoother operation**
- **Long life**
- **Minimal service**

Specially designed for continuous in production and for maximum efficiency of the operators.

For compressed air accessories please see page 255.

**14YP1 Series**

The 14YP1 is the most used pneumatic tool for production. Specially light and perfectly balanced it reduces the fatigue of the operator and allows

continuous wrapping on production. The housing is of reinforced strong LEXAN plastic. The tool is equipped with a 1,80 m hose.



Conductor Diameter	 weight (tool only)	with Back force spring for thin Conductor-ø	series Designation	Model number
mm	AWG	g		
0,25-1,0	30-10	390	<b>14YP1-37-A</b>	<b>26100AA5</b>
0,25-0,6	30-20	390	<b>14YP1-37-C</b>	<b>26110AA4</b>

**Air requirement:** 5,5 to 7 bar (80 to 100 psi)  
**Air consumption:** By 20% utilization factor: 23 litre free air per minute  
**Free rotation speed:** 3700 rev/min

**14YM1 Series**

This tool has been especially designed for wrapping panels in horizontal position when terminals are difficult to reach (radio and TV-sets, numerical

controls, etc. ...). Aluminium and steel housing. Equipped with a 1,80 m hose.



Conductor Diameter	 weight (tool only)	with Back force spring for thin Conductor-ø	series Designation	Model number
mm	AWG	g		
0,25-1,0	30-18	340	<b>14YM1-37-A</b>	<b>26300AA1</b>

**Air requirement:** 5,5 to 7 bar (80 to 100 psi)  
**Air consumption:** By 20% utilization factor: 23 litre free air per minute  
**Free rotation speed:** 3700 rev/min.

### Hand Squeezed Tools

These tools are normally used for occasional wrapping. With no external power requirement - operated only by hand - these tools are always ready for use. These light and easily operated tools find their place in any serviceman's tool-kit.



#### 14 HP-1C Series

The 14HP-1C consists of a sturdy Lexan plastic frame with a built-in gearing. Squeeze the large trigger and a quality solderless connection is made. The universal collet accommodates all wrapping bits and sleeves. One squeeze of the trigger provides 10 rotations of the bit.

Note: The tool is mounted with an „A“ nose piece. In this case the „C“ does not mean „Backforce nose piece“.

The model number of the tool does not include the wrapping bit and the sleeve. For selection of bit and sleeves please refer to pages 239 to 248.

Conductor Diameter	mm	AWG	weight (tool only) g	with Back force spring for thin Conductor-ø	series Designation	Model Number
0,25-0,65		30-22	260		14HP-1C	280 00AC1



Smaller and lighter than many simple screwdrivers. With a manual tool and an unwrapper the serviceman can make changes and repairs rapidly and simply.

A manual tool (only 40 grams) consists of a plastic handle, a wrapping bit and a simplified sleeve. The wire is wrapped by manual rotation of the tool and the connection is perfect.

**Breakdown of parts comprising a manual tool**

Handle	+	Wrapping bit	+	Simplified Sleeve	=	Simplified Sleeve replacing stationary sleeve (page 239 - 248)
p/n		p/n		p/n		
				517 228	}	507 100
				517 229		502 129
		according to				
		the application		517 230		512 056 or 506 999
517 219		select				
		on pages		517 231		18 840
		241-242		517 232		
						26 245
				517 233		18 640

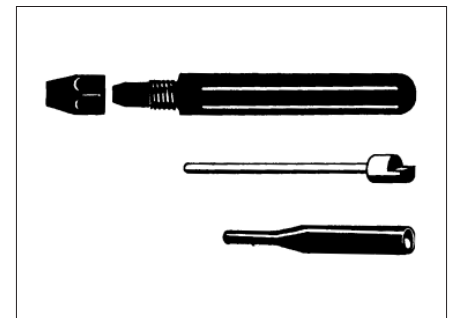

**Example:** The manual tool for conductor 0,25 mm (AWG 30) and terminal 0,6 mm sq. on a 2,54 mm grid consists of:  
 handle **517219**  
 + bit **507063**  
 + sleeve **517228**  
 Pneumatic Strapping Tool



Bus bars are expensive and cannot always be used. The hand strapping tool can offer a simple solution for the interconnection of feed lines and grounds.

Using a cheap bare wire, reliable wrapped straps can be made. The use of the hand strapping tools is not bound to a specific grid spacing.



### How to make Wire-Wrap-strapping connections

- Bare wire has inserted in the hole of the back of the hand tool. Bend the wire at the tip of the wrapping bit and hold it against the sleeve.
- Position the hand strapping tool with the bit terminal hole on the selected terminal. Rotate the tool until you have obtained the recommended of turns around the terminal.

A Hand Strapping Tool (40 grams) consists of:

a handle, drilled all the way through + a strapping bit + a strapping (or simplified)sleeve

p / n p / n p / n.

521124 according to the application

**Example:** Hand Strapping Tool for bare wire 0,4 mm diameter ( AWG 26) and for terminal 1,0 x 1,0 mm on a grid spacing of 5,08 mm consists of:

- a handle **521124**
- + a strapping bit **501332**
- + a strapping sleeve **517230**

### Strapping Bit and Sleeves

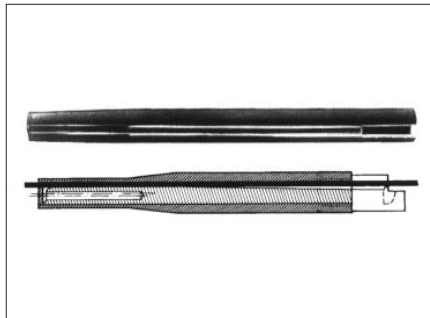

Conductor Diameter mm	AWG	Terminal	a strapping Bit p / n	Sleeve p / n	recommended number of turns
0,25	30	0,6 x 0,6	<b>501 866</b>	<b>517 228</b>	8
0,32	28	0,6 x 0,6	<b>511 202</b>	<b>517 228</b>	7
		0,635 x 0,635			7
0,4	26	0,6 x 0,6	<b>509 207</b>	<b>517 228</b>	6
0,4	26		<b>501 332</b>	<b>517 230</b>	6
0,5	24	1,0 x 1,0	<b>503 912</b>	<b>517 230</b>	5
		0,91 x 1,22			5
0,5/0,65	24/22	0,8 x 1,4	<b>509 242</b>	<b>517 231</b>	5/4
		0,8 x 1,6			4
0,65	22	1,14 x 1,14	<b>501 550</b>	<b>517 231</b>	4
0,8	20		<b>501 519</b>	<b>517 231</b>	4

- The other features of the bits and sleeves are listed on page 241.

### Wrapping Bits and Sleeves

The connection made by means of the Wire-Wrap bits meet the official specifications as follows:

DIN EN 60 352-1 for Germany, NFC 93021 for France, MIL-STD 1130 and EIA Std RS 280 for USA. DEFSTD 59-49, BTSPECD 2556 A.

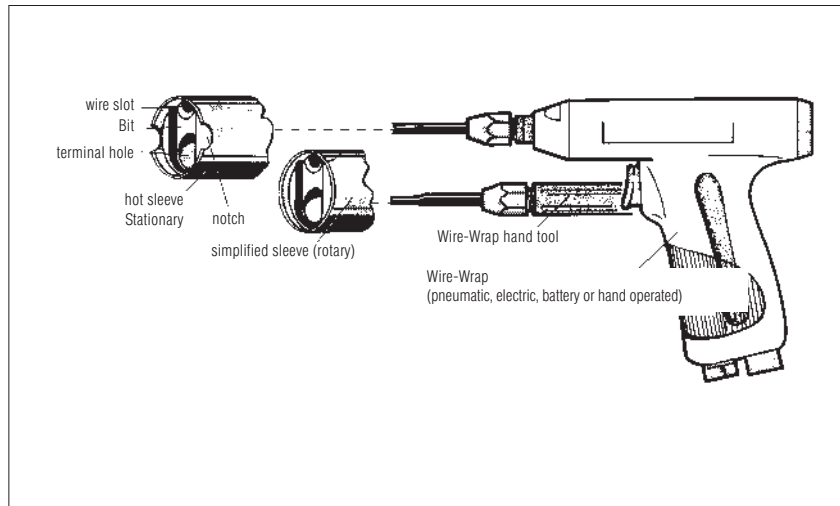

The solid conductor having been inserted in the wire slot is wrapped around the terminal. The sleeve guides the wire during the process.

Our wrapping bits and sleeves fit all the wrapping tools!

To mount the bit and the sleeve in the wrapping tool, loosen the collet nut. Insert the bit, gently rotating it in order to find the right position of the bit tang in the tool coupling. Then insert the sleeve, gently rotating it to find the positioning pin. When bit and sleeve are in place, tighten the collet nut with the fingers. Do not use a spanner.

In the case of type „C“ tools take care to not compress the backforce spring before tightening the collet nut. It must be possible to push the bit into the sleeve when the collet nut is tight.

#### Manual Tool

Insert the bit to locate the bit tang in the tool coupling. Insert the sleeve as far as possible; the angular position of the sleeves has no importance.

**Check the bits regularly by doing the strip force- and unwrap test. Please use the Wire-Wrap test sheet on page 258.**

### Extension Adapter Assembly

When connections have to be made on difficult to reach terminals, the bit and the sleeve can be mounted on an extension adapter.

Types Series	Length/L		p / N
	mm	g	
14YP1/14G2	50	30	505473
14YB2	100	60	990 241
14YB2	150	90	990 240



### Selection of Wrapping Bits and Sleeves

#### Application:

Wire diameter, Dimensions of Terminal, Grid System, Connection Style

#### Example:

Solid wire with conductor 0,25 mm (AWG 30) and insulation 0,55 mm diameter to be wrapped on a terminal a x b = 0,75 x 0,50 mm, terminal length 13,50 mm on a spacing of 2,54 mm - a MODIFIED connection is required.

#### Solution:

In the table „Technical Features of Wrapping Bits and Sleeves“ locate column (1): Conductor diameter, and column (2): connection style.

#### Example:

Conductor diameter 0,25 mm (AWG 30) and „MOD“.

#### Find:

„Terminal Diagonal from/to (column 3 in the chart on page XX). Using side „a“ = 0,75 mm and side „b“ = 0,50 mm calculate the theoretical diagonal = 0,90 mm. the actual diagonal is 0,90 - 0,04 = 0,86 mm (0.04 mm is the terminal corner radius allowance). For bit 507573 the terminal diagonal is from 0,84 to 0,92 mm.

#### Check maximum insulation diameter - column 4 - (applicable only to MODIFIED connections)

The insulation diameter is 0,55 mm. The bit 507573 can accept a maximum insulation diameter of 0,60 mm.

Clearance between sleeve and adjacent wrapped terminal use the formula:  
**Effective Radius + Wire diameter +  $\frac{a}{2} \leq \text{Spacing}$**

The bit 507573 with the sleeve 507100 has an effective radius of 1,55 mm. So: 1,55 + 0,55 + 0,375 < 2,54 mm.

**Determine** that the Strip Length (column 7) gives the required number of turns (column 8). This relationship depends on the wire diameter and the dimensions of the terminal.

In our example: strip length: 25 mm is correct.

- When using a terminal locator 14YN use the following sleeves:

517 101 instead of 507 100  
 517 168 instead of 502 129

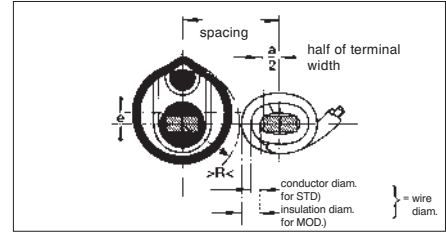
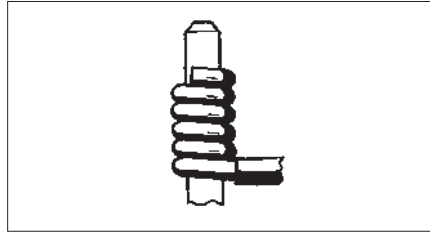
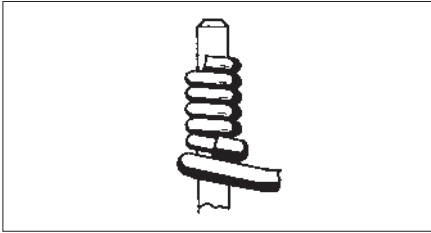

#### MOD. = MODIFIED

A connection is called MODIFIED when there is a turn of insulation at the base of the wrap. This turn of insulation will reinforce the connection against shocks and vibrations.

#### STD. = STANDARD

A connection is called STANDARD when there is no turn of insulation at the base of the wrap. The use of STANDARD connections makes the wrapping of thicker wires in a determined spacing possible (e.g. power supply lines).

Effective Radius (**R**) is the radius of the circle covered by the bit + sleeve combination when the tool rotates. As many bits have an excentric terminal hole axis, the (**R**) is not always half of the sleeve outside diameter.

$$>R < + \text{Wire-Diam.} + \frac{a}{2} \leq \text{Spacing}$$

Chart for Terminal diagonals

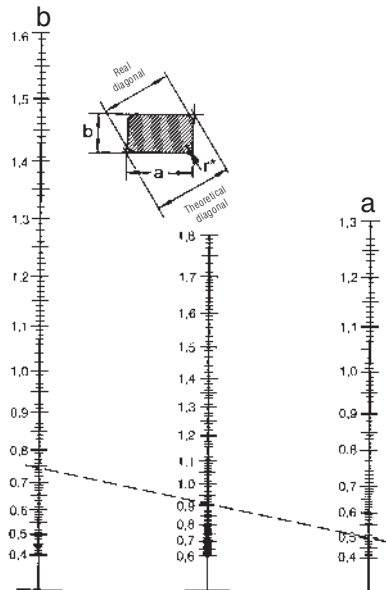

AWG	Diameter mm	Cross-section mm <sup>2</sup>
34	0.16	0.021
32	0.202	0.032
31	0.227	0.040
30	0.2555	0.050
29	0.286	0.064
28	0.321	0.080
27	0.361	0.102
26	0.405	0.128
25	0.455	0.163
24	0.511	0.205
23	0.573	0.259
22	0.644	0.325
21	0.723	0.412
20	0.813	0.519
19	0.912	0.652
18	1.024	0.826
17	1.151	1.039
16	1.290	1.309
15	1.450	1.652
14	1.628	2.084
13	1.829	2.627
12	2.053	3.308
11	2.304	4.168
10	2.588	5.262

1	2	3	4	5	6	7	8	Note			
Conductor Diameter	Wrap Type	Wrap Bit	Terminal diagonal from/to	Terminal hole diam. x terminal hole depth	max. insulation diam.ø	sleeve (stationary)	effective radius >R<	average strip-length Win	recom-mended number of turns		
mm (AWG)	MOD. STD.	p / n	mm	mm	p / n	mm	mm	for terminal mm			
0,25	(30)	MOD.	<b>501 097</b>	0,67 / 0,77	0,79x19	0,68	<b>507 100*</b>	1,67	23	8	0,5 x 0,5
			<b>507 063</b>	0,78 / 0,87	0,9x19	0,60	<b>507 100</b>	1,55	25	0,6 x 0,6 / 0,635 x 0,635	
			<b>990 734</b>	0,78 / 0,87	0,9x28	0,60	<b>507 100</b>	1,55	25	0,6 x 0,6 / 0,635 x 0,635	
			<b>507 573</b>	0,84 / 0,92	0,94x19	0,60	<b>507 100</b>	1,55	25	0,6x0,6 / 0,635x0,635/0,5x0,75	
			<b>519 936</b>	0,79 / 0,95	0,99x19	0,70	<b>507 100</b>	1,72		0,6x0,6 and alloy wire	
			<b>507 502</b>	1,04 / 1,12	1,14x19	0,68	<b>507 100</b>	1,8	30	0,56x0,91 and regular copper wire	
			<b>508 105</b>	1,35 / 1,45	1,48x25	0,68	<b>502 129</b>	2,36	38	1,0x1,0 and alloy wire	
			<b>501 381</b>	1,52 / 1,62	1,65x25	0,68	<b>512 056</b>	2,72	43	1,14x1,14 and alloy wire	
			<b>990 891</b>	0,59 / 0,64	0,65x15	0,49	<b>511 274</b>	1,21	20	0,46 x 0,45	
			STD.	<b>500 352</b>	0,69 / 0,77	0,79x19	-	<b>507 100</b>	1,69	23	8
STD.	<b>500 353</b>	0,81 / 0,89	0,91x19	-	<b>507 100</b>	1,55	25				
0,3	(28)	MOD.	<b>509 278</b>	0,78 / 0,87	0,91x19	0,76	<b>507 100</b>	1,7	23	7	0,6 x 0,6 / 0,635 x 0,635
			<b>501 389</b>	0,84x0,92	0,99x19	0,91	<b>502 129*</b>	2,2	25		
			STD.	<b>508 748</b>	0,86 / 0,94	0,96x19	-	<b>507 100</b>	1,6	25	7
			STD.	<b>505 373</b>	1,68 / 1,75	1,88x25	-	<b>512 056</b>	2,66	40	
0,4	(26)	MOD.	<b>506 445</b>	0,59 / 0,98	0,99x19	0,79	<b>507 100</b>	1,88	23	6	0,6x0,6 / 0,635x0,635
			<b>511 250</b>	0,79 / 0,91	0,97x19	1,09	<b>507 100</b>	1,88	23	0,6x0,6 / 0,635x0,635 max. insulation diam.	
			<b>509 405</b>	0,87 / 1,28	1,3x25	0,86	<b>502 129</b>	2,18	25	0,56x0,91	
			<b>517 104</b>	1,22 / 1,42	1,5x25	1,04	<b>512 056</b>	2,54	31	1,0x1,0	
			<b>511 439</b>	1,22 / 1,42	1,5x2,5	1,04	<b>502 129</b>	2,41	31	1,0x1,0 and silver plated wire	
			<b>502 118</b>	1,35 / 1,76	1,78x25	1,04	<b>512 056</b>	2,82	35	1,0x1,0 / 0,91x1,22 / 0,8x1,4 /	
			<b>506 781</b>	1,6 / 1,86	1,88x25	1,04	<b>512 056</b>	2,84	38	0,8x1,6 / 1,14x1,14 / 0,8x1,6 / 1,14x1,14	
0,4	(26)	MOD.	<b>519 070</b>	1,37 / 1,88	1,91x28,7	1,17	<b>18 840</b>	2,97	38		
0,5	(24)	MOD.	<b>519 070</b>	1,37 / 1,88	1,91x28,7	1,17	<b>188 40</b>	2,97	38		
0,4	(26)	STD.	<b>505 279</b>	0,59 / 0,98	0,99x19	-	<b>507 100</b>	1,73	23	6	
			<b>504 910</b>	1,47 / 1,86	1,88x25	-	<b>512 056</b>	2,66	38		
0,5	(24)	MOD.	<b>505 415</b>	0,61 / 1,1	1,12x25	1,12	<b>502 129</b>	2,49	20	5	0,6x0,6 / 0,635x0,635 / 0,56x0,91
			<b>506 991</b>	1,19 / 1,69	1,7x25	1,04	<b>506 999</b>	2,54	28	1,0x1,0 / 0,91x1,22 / 0,8x1,4 / 1,14x1,14	
			<b>504 155</b>	1,25 / 1,74	1,75x28	1,27	<b>18 840</b>	3,02	28	1,0x1,0 / 0,91x1,22 / 0,8x1,4 / 1,14x1,14	
			<b>26 263</b>	1,37 / 1,86	1,88x28	1,17	<b>18 840</b>	2,97	38	1,0x1,0 / 0,91x1,22 / 0,8x1,4 / 0,8x1,6 / 1,14x1,14	
0,5	(24)	STD.	<b>502 134</b>	0,61 / 1,1	1,12x25	-	<b>502 129</b>	2,12	20	5	
			<b>512 058</b>	1,38 / 1,88	1,89x25	-	<b>512 056</b>	2,65	30		
0,65	(22)	MOD.	<b>504 939</b>	1,25 / 1,86	1,88x25	1,32	<b>18 840</b>	3,35	28	4	1,0x1,0 / 0,91x1,22 / 0,8x1,4 / 0,8x1,6
			STD.	<b>505 413</b>	1,25 / 1,86	1,88x25	-	<b>18 840</b>	3,0	28	4
			<b>18 632</b>	1,55 / 2,17	2,18x25	-	<b>18 840</b>	3,16	30		
			<b>18 635</b>	2,49 / 3,11	3,12x25	-	<b>18 640</b>	3,6	36		
0,8	(20)	MOD.	<b>26 495</b>	1,07 / 1,86	1,88x25	1,5	<b>26 245</b>	3,81	28	4	1,0x1,0 / 0,91x1,22 / 0,8x1,4 / 0,8x1,6 / 1,14x1,14
			STD.	<b>507 356</b>	1,07 / 1,86	1,88x25	-	<b>18 840</b>	3,06	28	4
			<b>18 633</b>	1,5 / 2,3	2,31x25	-	<b>26 245</b>	3,74	32		
			<b>18 637</b>	2,31 / 3,11	3,12x25	-	<b>18 640</b>	3,81	36		
1,0	(18)	MOD.	<b>504 908</b>	1,55 / 1,86	1,88x25	1,78	<b>18 640</b>	3,83	30	4	1,14x1,14
			STD.	<b>504 222</b>	1,55 / 1,86	1,88x25	-	<b>26 245</b>	3,81	30	4
Strapping Bits and Sleeves											
0,25	(30)	STD.	<b>501 866</b>	0,81 / 0,89	0,99x19	-	<b>517 228</b>	2,04	-	7	0,6x0,6 / 0,635x0,635
0,32	(28)	STD.	<b>511 202</b>	0,79 / 0,89	0,96x19	-	<b>517 228</b>	1,65	-	6	0,6x0,6 / 0,635x0,635
0,4	(26)	STD.	<b>509 207</b>	0,58 / 0,97	0,99x19	-	<b>517 228</b>	1,85	-	6	0,5x0,5 / 0,6x0,6 / 0,635x0,635
			<b>501 332</b>	1,47 / 1,87	1,88x25	-	<b>517 230</b>	2,65	-	6	1,0x1,0 / 0,91x1,22 / 0,8x1,4 / 0,8x1,6 / 1,14x1,14
0,5	(24)	STD.	<b>503 912</b>	1,38 / 1,88	1,89x25	-	<b>517 230</b>	2,65	-	5	1,0x1,0 / 0,91x1,22 / 0,8x1,4 / 0,8x1,6 / 1,14x1,14
0,5-0,65	(24-22)	STD.	<b>509 242</b>	1,37 / 1,87	1,88x25	-	<b>517 231</b>	2,87	-	4	1,0x1,0 / 0,91x1,22 / 0,8x1,4 / 0,8x1,6 / 1,14x1,14
(0,65	(22)	STD.	<b>501 550</b>	1,25 / 1,87	1,88x25	-	<b>517 231</b>	3,05	-	4	1,0x1,0 / 0,91x1,22 / 0,8x1,4 / 0,8x1,6 / 1,14x1,14
0,8	(20)	STD.	<b>501 519</b>	1,07 / 1,87	1,88x25	-	<b>517 231</b>	3,1	-	4	1,0x1,0 / 0,91x1,22 / 0,8x1,4 / 0,8x1,6 / 1,14x1,14

\* For Micro-Wire-Wrap-technology see page 249.

## Bits and Sleeves for modified connections (DIN EN 60 352-1)

	Mini			Midi			Maxi	
Conductor diam.Ø (mm) d¹ (AWG)	0,25 (30)	0,32 (28)	0,4 (26)	0,4 (26)	0,5 (24)	0,65 (22)	0,8 (20)	1,0 (18)
Strip length (mm)								
d² insulation diam.-Ø (mm)	0,58	0,58	0,67	1,04	1,17	1,1	1,5	1,78
spacing (mm)	2,54	2,54	2,54	5,08	5,08	5,08	7,62	7,62
a x b = terminal 0,5 x 0,5	50 1097 50 7100 (517228)							
terminal 0,6 x 0,6 (0,635 x 0,635)	50 7063 50 7100 (517228)	50 9278 50 7100 (517228)	50 7063 50 7100 (517228)					
terminal 0,56 x 0,91	50 7502 50 7100 (517228)							
terminal 1,0 x 1,0				51 7104 51 2056 (517230)	50 4155 18 840 (517231)			
terminal 0,91 x 1,22								
terminal 0,8 x 1,4								
terminal 0,8 x 1,6								
terminal 1,14 x 1,14				50 2118 51 2056 (517230)	26 263 18 840 (517231)	50 4939 18 840 (517231)	26 495 26 245 (517232)	50 4908 18 640 (517231)
result	 8	7	6	6	5	4	4	4

### Explanation of the grey fields of the chart

 = Strip length mm

**Part-Number:**

**Bit**

**Stationary Sleeve**

**Simplified Sleeve - rotary -**

for all „Wire-Wrap“ Tools (strapping tools excepted)

for all „Wire-Wrap“ Tools, excepted of:

for manual tools

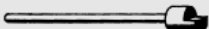



## Cut Strip Wrap Bits and Sleeves for MODIFIED connections

### CSW (Cut – Strip – Wrap)

C.S.W. Bits and Sleeves can be used with following tools:

**For C.S.W. Bits use tools with „A“ nose-piece only**

The C.S.W. bits and sleeves cut the wire to the correct length, strip the insulation and wrap the correct number of turns in one operation.

The purpose of the C.S.W. Bits and sleeves is not to replace conventional wrapping, but to widen the field of operation of the Wire-Wrap technique.

For good results its important to keep to the wire specifications on page 242.

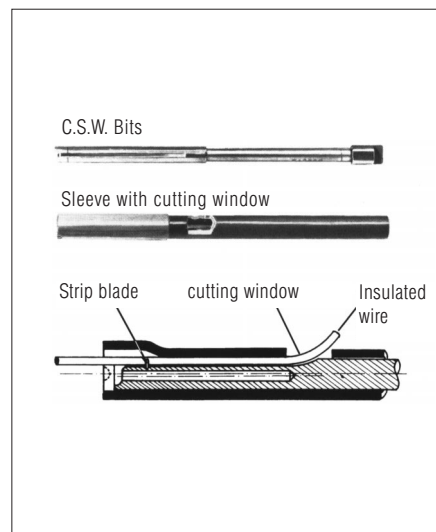

Conductor	Insulation	Terminal diagonal from/to	Effective radius >R<	Terminal hole depth	C.S.W. bit part no.	Sleeve with cutting part no.	Note	Result
mm (AWG)	mm	mm	mm	mm	part no.	part no.		for terminal mm
0,25 (30)	0,51-0,56	0,76-0,86	1,79	25,4	<b>990 063</b>	<b>990 064</b>	7	0,6x0,6 0,635x0,635
	0,48-0,55	0,76-0,86	1,65	25,4	<b>990 764</b>	<b>990 765</b>	7	0,6x0,6 0,635x0,635
	0,48-0,52	0,76-0,86	1,65	28,2	<b>990 841</b>	<b>990 765</b>	7	0,6x0,6 0,635x0,635
0,40 (26)	0,64-0,71	0,76-0,86	2,08	25,4	<b>527 812</b>	<b>527 813</b>	7	0,6x0,6 0,635x0,635
	0,70-0,79	0,76-0,86	2,08	25,4	<b>990 995</b>	<b>527 813</b>	7	0,6x0,6 0,635x0,635
	0,64-0,74	1,65-1,75	2,95	25,4	<b>522 205</b>	<b>522 204</b>	7	0,8x1,6
	0,64-0,74	1,50-1,60	2,85	25,4	<b>522 203</b>	<b>522 204</b>	7	1,0x1,0 1,14x1,14
	0,79-0,89	1,50-1,83	3,25	25,4	<b>522 202</b>	<b>522 201</b>	7	0,8x1,6
	0,86-0,99	1,37-1,47	3,25	25,4	<b>521 105</b>	<b>521 116</b>	6	1,0x1,0
	0,97-1,03	1,37-1,47	3,25	25,4	<b>521 105</b>	<b>990 435</b>	6	1,0x1,0
	0,66-0,74	1,37-1,47	2,82	25,4	<b>519 926</b>	<b>519 927</b>	6	1,0x1,0
	0,97-1,05	1,37-1,47	3,35	25,4	<b>990 681</b>	<b>990 435</b>	6	1,0x1,0
	0,64-0,71	0,76-0,86	2,08	28,2	<b>990 842</b>	<b>527 813</b>	7	0,6x0,6 0,635x0,635
	0,56-0,64	0,76-0,86	1,76	25,4	<b>990 844</b>	<b>990 845</b>	7	0,6x0,6
	0,75-0,85	1,37-1,44	2,82	25,4	<b>990 846</b>	<b>990 847</b>	6	1,0x1,0 1,3x0,6
0,40-0,50 (26/24)	0,76-0,91	1,37-1,47	2,78	25,4	<b>990996</b>	<b>990997</b>	7	0,6x1,3 1,0x1,0
0,50 (24)	0,74-0,85	1,37-1,47	3,25	25,4	<b>990 753</b>	<b>519 929</b>	6	1,0x1,0
	0,86-0,99	1,50-1,83	3,38	25,4	<b>519 066</b>	<b>522 201</b>	6	1,0x1,0 0,8x1,6
	1,02-1,14	1,68-1,78	3,48	25,4	<b>521 198</b>	<b>521 199</b>	6	0,8x1,6
	0,81-0,89	1,50-1,88	3,28	25,4	<b>990 046</b>	<b>522 201</b>	6	0,8x1,6
	1,02-1,14	1,50-1,83	3,38	25,4	<b>518 910</b>	<b>518 911</b>	6	0,8x1,4
	0,81-0,94	1,50-1,83	3,25	25,4	<b>518 910</b>	<b>519 929</b>	6	0,8x1,4 1,0x1,0
	1,02-1,09	1,37-1,47	3,35	25,4	<b>990 561</b>	<b>990 562</b>	5,5	1,0x1,0 0,91x1,22
	0,84-0,91	1,37-1,47	3,23	25,4	<b>519 928</b>	<b>519 929</b>	5,5	1,0x1,0 0,91x1,22
	1,02-1,14	1,50-1,83	3,38	25,4	<b>519 066</b>	<b>519 067</b>	6	1,0x1,0 0,80x1,60
	1,31-1,39	1,37-1,47	3,28	25,4	<b>990 579</b>	<b>522 212</b>	5	1,0x1,0
0,50-0,60 (24/22)	1,14-1,27	1,75-1,83	3,38	25,4	<b>518 931</b>	<b>518 932</b>	6	0,8x1,6
0,60 (22)	1,16-1,25	1,37-1,47	3,38	25,4	<b>990 646</b>	<b>522 212</b>	5	1,0x1,0
	1,14-1,27	1,50-1,60	3,28	25,4	<b>522 211</b>	<b>522 212</b>	5	1,14x1,14 0,8x1,4
	0,94-1,02	1,37-1,47	3,48	25,4	<b>990 563</b>	<b>990 562</b>	5	1,0x1,0
	1,04-1,12	1,37-1,47	3,38	25,4	<b>990 779</b>	<b>990 780</b>	5	1,0x1,0

### Wire Specifications for C.S.W. Connections

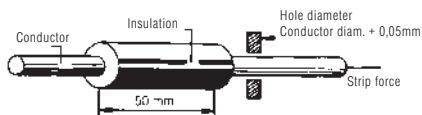

**Conductor:**

Copper wire with 20% minimum elongation at breakpoint.

**Wire plating:**

**Tinned or silver-plated conductor. The texture of wire plating must be smooth.**

**Concentricity of insulation:**

Within 80% minimum (ration of thinnest to thickest wall).

**Example:**

Semi-rigid PVC, FEP Teflon®, Kynar®, Tefzel®, Milene® Elongation at breakpoint: 125% min., 250% max.

If the adhesion between the conductor and the insulation is excessive, the conductor can be over-elongated by the C.S.W. bit and this will produce a brittle connection.

The strip force of 50 mm of insulation should not exceed the listed values.

**Each application has to be checked individually, especially when strip force does not meet the specifications.**

Conductor diam.		Strip force Newton max	Stripped length mm
mm	AWG		
0,25	30	3,4	
0,4	26	4,5	
0,5	24	5,5	50
0,65	22	8	

Milene® is a registered trademark of the Gore Wire Manufacturing Co.



### Finger operated Cutting Accessory

The attachment of a finger-operated cutting accessory to the wrapping tool is recommended for the **C.S.W. process**. With this accessory it is easy to cut a determined length of wire from the reel without having to lay down the wrapping tool. This accessory speeds up the operation.

Finger operated Cutting Accessory	g	Part no.
for 14YP1 14YM1	60	<b>990 600</b>
for 14YB2		<b>990 601</b>

#### Accessory

Spring Hook

A useful aid for wire forming. This tool is must for routing wires on dense wire-wrapped panels.

10 g

**532748**



## Cut Strip Wrap Combinations Bits and Sleeves (SIEMENS Type)

A new product result of many years of experience in the field of wrapping technique.

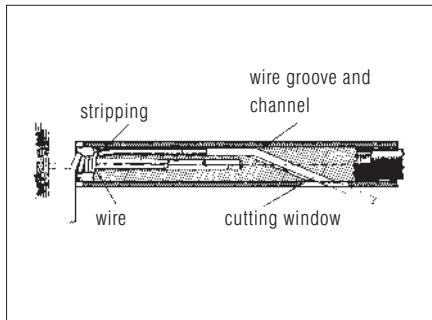

- Cuts the wire
- Strips the insulation with one tool only
- Wraps and Dresses the wire in one operation only.

Available for usual wires with a conductor diameter of 0,4 mm (AWG 26) and of 0,5 mm (AWG 24) and for terminals 1,0 x 1,0 mm on a 5 mm grid.

**The C.S.W. attachment consists of: a wrapping bit with a stripping blade and a sleeve with a cutting window.**

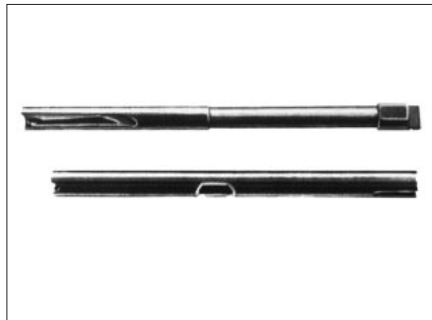

### Advantages:

**COST REDUCTION and BETTER QUALITY**

- Wire insertion as usual, so no re-training of operators.
- No apparent rotary parts, so no danger for the operator and for the panel.
- No wire preparation - the wire comes from the reel.
- Constant number of turns, because of constant strip length.
- Can be used on a 5 mm standardized grid because of well adapted design.
- Higher quality - more automated process and less influence of the operator.
- No excentricity of the terminal hole, so better operation with semi-automatic machines.



Wire (for example)  
6Y4Y 1x.../...  
Siemens  
specification  
SN54233\*

Terminal (for example)  
1,0x1,0x20  
DIN EN 60352-1

Result

**C.S.W.  
Attachment  
(bit and sleeves)**

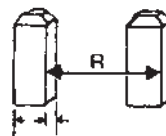
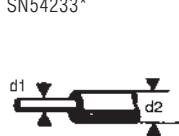

mm	(AWG)	mm	mm	mm	mm	part no.
0,4	26	0,9±0,05	1,0x1,0	5	6	<b>914 126</b>
0,5	24	1,0±0,05	5			<b>914 124</b>

\* With **adhesive** ETFE-insulation

Bit and sleeve cannot be exchanged separately.

## Solderless connections conforming

DIN EN 60 352-1 part 2 with C.S.W. attachment (SIEMENS Type)

### 1. Mounting of the wrapping assembly

The wrapping attachment (bit and sleeve) is mounted as usual on the convenient tool:

Loosen the collet nut. Insert the bit, gently rotating it in order to find the correct position of the bit tang in the bit coupling. Then, insert the sleeve gently rotating it to find the positioning pin. Tighten the collet cut with the fingers. Do not use a spanner.

### 2. Wire insertion

Insert the insulated wire in the slot (excentered hole) until it comes out of the cutting window. (The stripped insulation of the previous connection is pushed out of the wire slot by this operation). Form the wire in the notch located on the side of the sleeve tip. Hold the wire without pulling.

### 3. Position the tool

Position the tool inserting the selected terminal in the central hole of the bit. As long as it is held, the wire that has been previously formed, cannot slip from the wire slot. It is possible to locate the bit on the selected level of the terminal. When wrapping the second end of the wire, it is possible to adjust the wire length in pulling on the part of the wire coming out of the cutting window.

### 4. Wrapping

Do not push too hard! Do not pull back! By the rotation of the bit, the insulation is stripped and several turns of wire are wrapped on the terminal. simultaneously the wire that comes out of the cutting window is cut and a constant number of turns will be obtained.

### 5. Result: A modified Wire-Wrap Connection

The bit will first wrap a turn of insulation at the base of the connection. This turn of insulated wire will improve the resistance of the connection

to chocks and vibrations. A high pressure is created between the contact points of the wire and the sharp edges of the terminal. This pressure will remain after the wrapping process. The indentation of the wire by the sharp edges of the terminal will displace any oxidized surface and the high pressure will create a gas-tight connection. the electrical conductivity and the mechanical stability are excellent and meet the official specifications for solderless connections.

### 6. To work from the reel

The attachment of a Finger Operated Cutting Accessory is recommended for the C.S.W. process. Ordinary shears can deform the end of the wire and make its insertion in the wire slot difficult.

Moreover, when using the Finger Operated Cutting Tool, there is no need to lay down the wrapping tool to cut the wire from the reel.

### 7. Dressing of the wire

Because of the special shape of the wire slot, it is possible to pull the wire through the bit and to dress the wire in the channels between the terminals in using the bit itself.

The correct length of the wire can be easily adjusted.

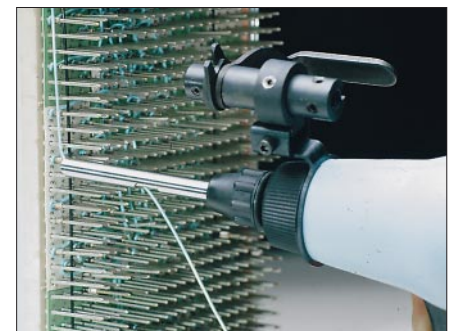
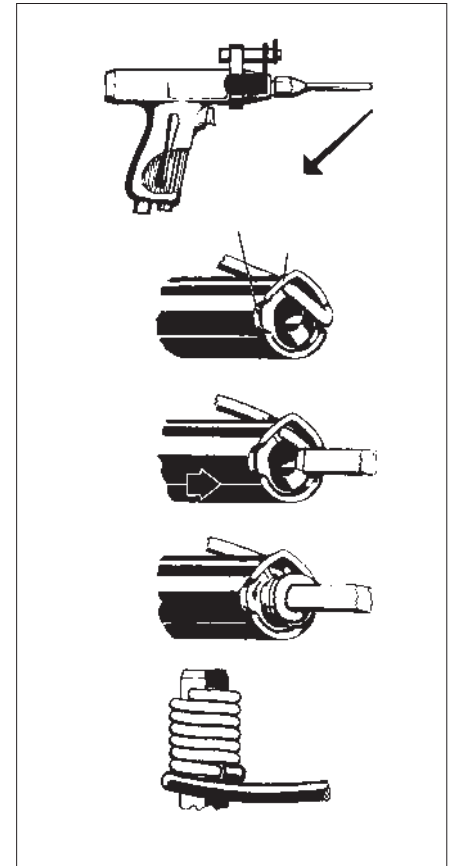



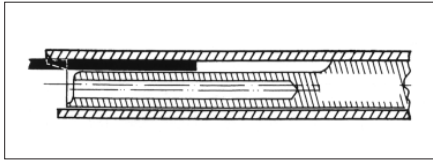

Sleeve for Secondary Connections



Special sleeve for Secondary Connections

## Wrapping Bits and Special Sleeves for Secondary Connections

Secondary connections are made by means of a STANDARD wrapping bit with a special sleeve. The result is a gas-tight, reliable permanent connection that meets the official specifications. (DIN EN 60 352-1).

1. Insert the correct pre-cut length of bare wire in the wire slot of the bit.
2. Insert the stripped end of the standard wire in the terminal hole of the bit.
3. Position the tool so that the terminal is inserted in the terminal hole.
4. Wrap as usual.

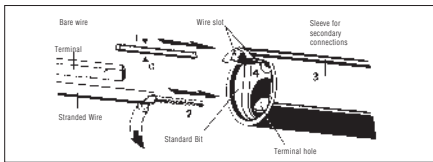
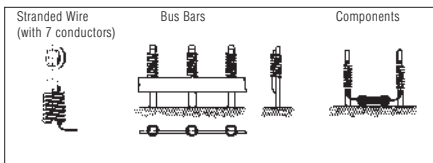

Bare Wire Diam.	Sleeve for Secondary Connection	to be used instead of sleeve	Increase of effective Radius (R)	Number of turns of Bare Wire	Average strip length of stranded Wire	Recommended diameter of stranded Wire	For Terminal	Minimum Strip force
mm (AWG)	Part no.		mm		mm	from/to mm (AWG)	mm	(N)=1N ca. 0,1 kg
0,5 (24)	<b>501 073</b>	512 056	+0,25	7	3,5	0,5 / 0,7 (26 / 23)	1,0 x 1,0 0,91 x 1,22 0,8 x 1,4 0,8 x 1,6 1,14 x 1,14	3,0 / 4,0 (30 / 40)
0,65 (22)	<b>501 074</b>	18 840	+0,24	7	4,5	0,8 / 1,0 (22 / 20)	0,91 x 1,22 0,8 x 1,4 0,8 x 1,6	8,0 / 9,0 (80 / 90)

### Some Examples of applications

Bare wire diam.	Stranded Wire diam.	Terminal	Bit	Sleeve
0,5 (24)	0,65 (24)	1,0 x 1,0	512 058	501 073
0,65 (22)	0,8 (22)	0,1 x 1,6	18 632	501 074

## Special Pneumatic Tool for Wire AWG 34

Specially designed for high density wiring on a grid spacing of 1,27mm (0.05").

- Even in the most sophisticated miniaturized electronic devices, it can be advantageous to connect integrated components by means of wires.
- The new AWG 34 tool permits the wrapping of AWG 34 wires on a 0.05" (1,27 mm) terminal spacing.
- Any danger of damaging temperature sensitive integrated components is eliminated.

- Ideal to make prototypes, small series, researches specially when circuitry changes are expected.
- Sturdy construction; aluminium and steel housing.
- Low weight.



Conductor Diameter		Wheight	Part-No.
mm	AWG	g	
0,16-0,5	34-24	250	<b>9407 62 A5</b>

### General Specifications

Conductor size: 34 AWG

Conductor-

Diameter: 0,16 mm, OFHC copper or of Alloy 134.

Insulating diameter: 0,254 mm + 0,012 mm  
Insulating materials are the same as those used for AWG 30

Terminals: 0,3 x 0,3 mm

Terminals- Material: PhosphorBronze or Beryllium copper  
The same criticism as like AWG 30

Radius of the edge of the terminal: 0,025 mm max.

Terminal length: Recommended length for 3 connections: 8 mm

Connections: Recommended number of turns: 7-8 with bar wire: 1 1/2 turns with insulation  
Minimum stripforce: 0,679 kg = 6,7N

### Recommendations

- When the 34 AWG wrapping is performed without the aid of a terminal locator, a large static magnifying lense with incorporated illumination should be used (Magn: 2 to 3)
- The 34 AWG tool is used like a pencil. Better results are obtained when the operator has the possibility to rest the elbows during the wrapping operation.
- It is advisable to mount the panel to be wrapped in a fixture. The angle of the fixture should be adjustable according to the comfort of the operator.
- Quantities of wires of various lengths have to be pre-cut and pre-stripped, preferably by means of an automatic stripping machine.

Conductor	Insulation	Terminal	Terminal hole depth	Wrap Bit	sleeve stationary	Unwrapper	average strip length	recommended number of turns	
mm (AWG)	mm	mm	mm	Part-No.	Part-No.	Part-No..	mm		
0,16 (34)	0,19	0,4x0,4	1,50	10	<b>990 566</b>	<b>990 567</b>	<b>990 402</b>	12	7-8
	0,25	0,3x0,3	1,25	10	<b>990 876</b>	<b>990 877</b>	<b>990 204</b>	10	1 turn
	0,25	0,6x0,6	2,54	10	<b>990 967</b>	<b>511 274</b>	<b>505 084</b>	25	with insulation
	0,25	0,4x0,4	1,27	10	<b>990 878</b>	<b>990 879</b>	<b>990 402</b>	12	

### Hand Squeeze Tool used as Unwrapping Tool



- The 14HP-1C tool, model 28 00 AC1 (clockwise rotation) can be used to unwrap „A“ connections of 14F, 14FV and 14FS automatic machines.
- The 14 HP-1 CL tool, model 28 0210 AB2 (counter-clockwise rotation) can be used to unwrap normal, clockwise connections.
- Unwrapping bit-sleeve assemblies are listed below.



Conductor diameter		Terminal hole dia. and depth	outside diameter of bit	part no.
mm	AWG			

#### for unwrapping normal CW connections

0,25 – 0,40	30 – 26	1,02x25	2,36	<b>990 420</b>
0,40 – 0,60	26 – 22	1,78x25	3,18	<b>990 421</b>
0,40 – 0,60	26 – 22	1,78x25	3,96	<b>990 422</b>

#### for unwrapping CCW connections of „A“-tool 14F

0,25 – 0,40	30 – 36	1,02x25	2,36	<b>990 423</b>
0,40 – 0,60	26 – 22	1,78x25	3,18	<b>990 424</b>

Unwrap Bit-sleeve Asemblies for Wrap-Unwrap Tools 14R3 and HP-1C.

### Battery Tool used as Unwrapping Tool

#### Model 14R3

Description see page 234.



These tools can also be used to perform the „Unwrapping Test“ for checking possible brittleness of connections.

L = Left, or counter-clockwise tools for clockwise (normal connections)  
 R = Right, or clockwise tools for counter-clockwise connections.



### Manual Unwrapping Tools

These are used for quick and easy unwrapping when minor changes are required.

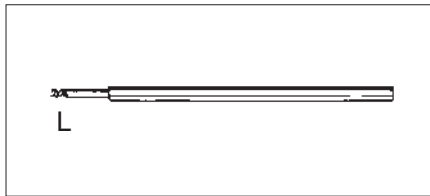

Conductor diam.		Terminal	Terminal hole	Part No.
mm	AWG			
0,2-0,4	32-26	0,5x0,5	0,9	<b>509 436</b>
		0,6x0,6	1,0	<b>505 084</b>
0,25-0,5	30-24	0,56x0,91	1,3	<b>509 489</b>
0,4-0,8	26-20	1,0x1,0	1,8	<b>504 769</b>
		0,91x1,22		
		0,8x1,4		<b>515 716</b>
		0,8x1,6		
0,5-1,0	24-18	1,14x1,14	1,8	<b>A31 478</b>
0,5-1,0	24-18	0,8x 2,4	3,18	<b>A25 195L</b>
		0,5x0,5	0,9	<b>511 203</b>

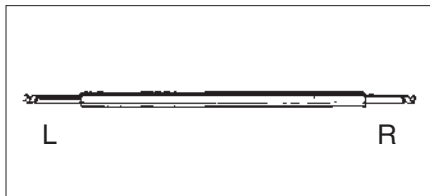

0,2-0,4	32-26	0,6x0,6	1,0	<b>505 244</b>
0,25-0,5	30-24	0,56x0,91	1,3	<b>511 225</b>
0,4x0,8	26-20	1,0x1,0		
		0,91x1,22	1,8	<b>A26 664</b>
		0,8x1,4		
		0,8x1,6		
0,5-1,0	24-18	1,14x1,14	1,8	<b>500 130</b>

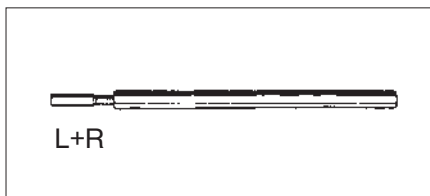

0,25	30	0,5x0,5	0,95	<b>515 666</b>
		0,6x0,6		
		with sleeve		
0,4	26	1,0x1,0	1,8	
		0,91x1,22		<b>515 665</b>
		0,8 x 1,4		
0,5	24	0,8x1,6	1,8	<b>515 664</b>
		1,14x1,14		



0,4-0,8	20-26	1,0 x 1,0		<b>420</b>
		0,8 x 1,6		
		with isolated, spring loaded sleeve		

for Wire-Wrap Tools:  
Conductor  
diameter

Series 14YB2

mm	AWG	g	Part No.
0,32	28	80	<b>990 503 28</b>
0,80	20	80	<b>990 503 20</b>



### Cutting and Stripping Device Type B 2

Wire is cut at the right place and stripped to the correct length by means of this super-light tool or attachment.

- Can strip any insulation material
- This unique cutting and stripping tool utilizes a blade design that cuts the entire diameter of insulation without damaging the conductor
- Strip length adjustable from 8 to 60 mm
- Insert wire in the cut and strip blades
- Press lever with finger. Tool can be adjusted for right or left handed operators.



- When the wrapping tool is equipped with a cutting and stripping accessory the stripped wire can be inserted in the wrapping bit and wrapped without laying down the tool.

The cutting and stripping part of the device can be mounted by means of a clamp on a wrapping tool as an accessory or mounted on a handle to make a cutting and stripping tool.

The lever can be easily mounted on the right or on the left of the tool according to the operator's requirements.



#### Replacement Stripping Blades

for Wire-Wrap Tools

Series 14YB2...

Series 14YL1 / 14YP

Conductor  
Diameter

mm

AWG

g

Part no.

Part no.

0,16

34

90

**990 508 34**

0,20

32

90

**990 508 32**

#### Spare knife blades fore stripping

Conductor  
Diameter

mm

AWG

Part no.  
Knife blade

A

Part no.  
Knife blade

B

0,25

30

**990 343**

0,40

26

**990 339**

**990 338**

0,50

24

**990 337**

**990 336**



Various Accessories

For a long and trouble-free operation of the pneumatic tools it is recommended to use clean, dry and lubricated air at the correct pressure. A good „lubri-control“ unit is the best friend of your air tool.

**Lubri-Control-Unit ( Filter-Regulator-Lubricator)**

Air inlet (thread)	Best range of application m <sup>3</sup> /min	Type Series	Part No.
R1/8"	0,03 –0,4	FRL018	<b>940 428 B8</b>

**Available:**  
 fixture elbow, part no. H 15024



**Air Hose with Fittings**

Air inlet (thread)	Type Series	Part No.
R1/8"	Air hose cpl. 1,8 m long	<b>A139 856</b>



**Oils (or equivalent) to be used:**

- |   |   |   |   |  |
|---|---|---|---|--|
|  |  |  |  |  |
| BV-Öl HTU<br>oder<br>BV-Öl E 100 extra  | ESSTIC 42   | TELLUS 46   | BP ENERGOL<br>HL 65   | MOBIL D.T.E<br>OIL Light   |

1.



### 1. Tool box for Wire-Wrap tool 14YB3...

The small handy tool box is for storing the 14YB3 tool with bits, sleeves and unwrapping tools.

Dimension in mm:	<b>Part no.</b>
330x240x85	

tool box for 14YB3...	<b>977 000</b>
-----------------------	----------------

2.



### 2. Strip Force Gauge

Spring gauge with dial. Supplied with two hooks compatible with standardized terminals. This gauge allows the regular checking of the quality of the Wire-Wrap connections.

Range	Scale-Division				<b>Part no.</b>
kg	(N*)	g	(N*)	g	
10	100	100	1	370	<b>912 968</b>
		midi			<b>914 414</b>
		mini			<b>914 415</b>

\*1N= ~0,1 kg

3.



### 3. Insulation Stripper

Very simple design for thermoplastic insulations. Insert wire in the wire hole until correct strip length is reached. Pull off. Insulation is rejected with next wire insertion.

Conductor diam.	max. insu- lation dia.	Color Code	<b>Type Part no.</b>	
mm	AWG	ø mm	g	
0,25	30	0,58	blue	<b>525 655</b>
0,32	28	0,65	green	<b>525 654</b>
0,25	30	0,58	blue	
+	+			<b>525 653</b>
0,4	26	0,8	red	
0,4	26	0,8	red	23 <b>525 652</b>
0,4	26	0,8	red	
+	+			<b>525 651</b>
0,5	24	1,17	yellow	
0,5	24	1,17	yellow	<b>525 650</b>

## Wire for solderless connections made by means of C.S.W. bits and sleeves

By means of this tooling (C.S.W. = Cut-Strip-Wrap) the insulated wire is stripped on a determined length and simultaneously wrapped around the terminal.

Tests have shown that ETFE-Tefzel insulated wires are specially well adapted to the C.S.W. technology. The wires listed in bulletin give excellent results.

To obtain good results with C.S.W. bits, it is important to use a wire that meets the specifications for diameter, concentricity, adhesion of the insulation and elongation of the conductor. Respect of tolerances is very important in this case.

### Easy operating. No re-training of operators.

The wire is inserted as usual in the wire slot of the bit. An accurate strip-length is obtained as the cutting window and the strip-blade have a fixed position.

The C.S.W. bits are easy to operated and offer the possibility to wrap on terminals located on narrow spacings.

1. Insert the wire in the wire slot
2. Position the wrapping bit terminal hole on the selected terminal
3. The wire is cut and stripped to a determined length in order to obtain the correct number of turns
4. The wire is simultaneously stripped and wrapped
5. Finished modified Wire-Wrap connection

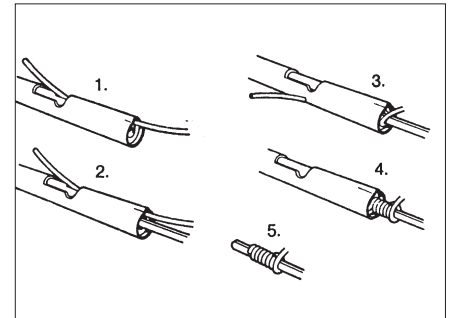

AWG	wire diam. mm	cross- section in mm	Ref. No.	Insulation diameter mm		Voltage	C.S.W. bits and sleeves
				min.	max.		
						VAV	
30	1 x 0,254	0,05	MTZ 30-130-2	0,48	0,51	250	990 764 / 990 765*
26	1 x 0,404	0,13	MTZ 26-126-2	0,64	0,70	250	527 812 / 527 813* 519 926 / 519 927*
24	1 x 0,510	0,20	MTZ 24-124-2	0,74	0,85	250	990 753 / 519 929*

\* Technical datas for C.S.W. bits see page 243

**Standard-Packing:**  
250 m Reel for AWG 26 and 24  
100 m Reel for AWG 30

**Colours:**  
Black, brown, red, orange, yellow,  
green, blue, purple, grey, white and  
natural.

**Minimum order:**  
1 Rule

modifications are subject to change  
without notice.

The conductors meets the specificati-  
ons of DIN 40500, MIL-W-16878 and  
has UL-approbation.



Description	Page
14YB3	260
14YG1	261
14R3	262
14YP1	263



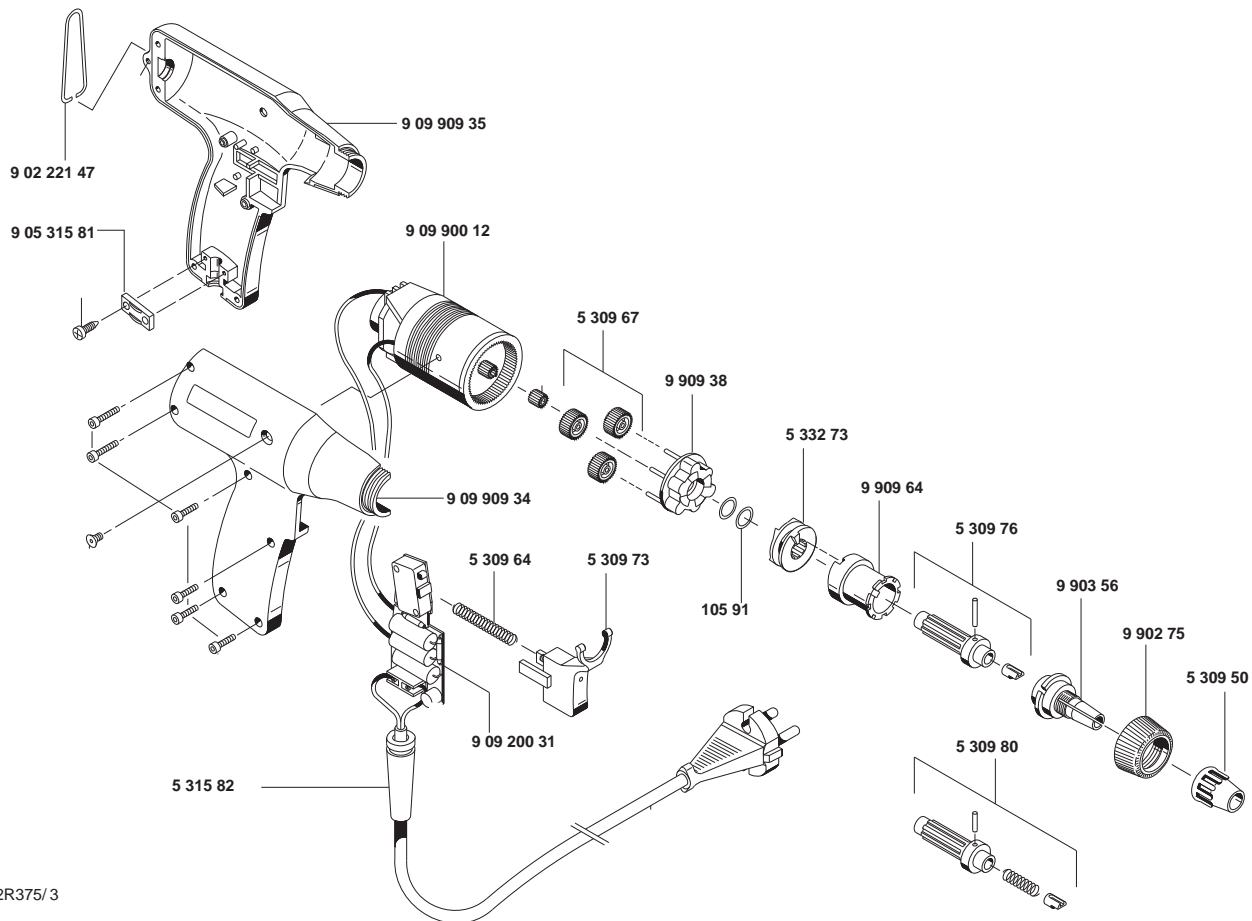

4D2R375/3

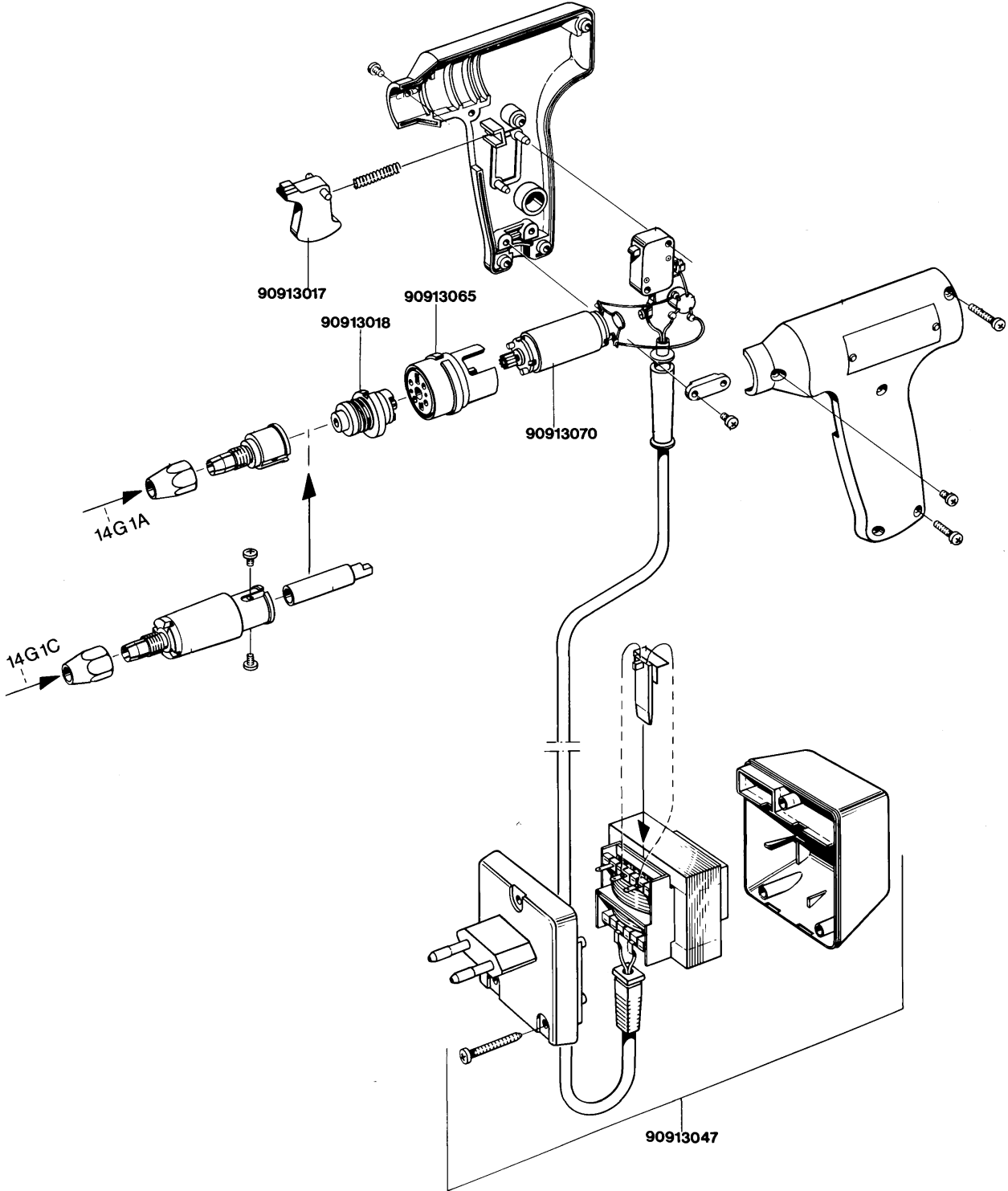

90990670 120V AC Standard  
 90990675 120V AC Backforce  
 90990680 220V AC Standard  
 90990685 220V AC Backforce

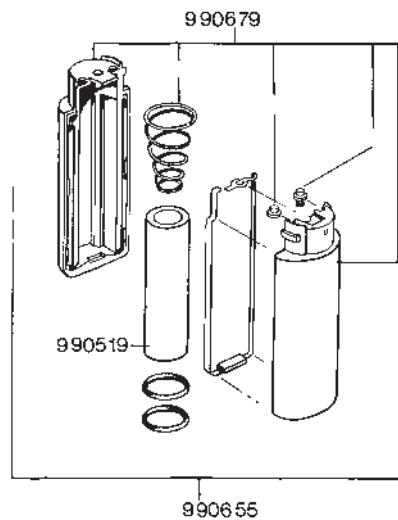
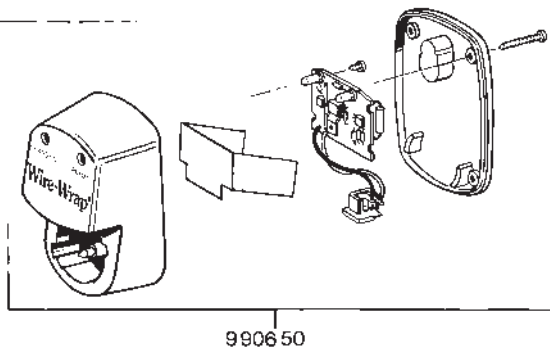
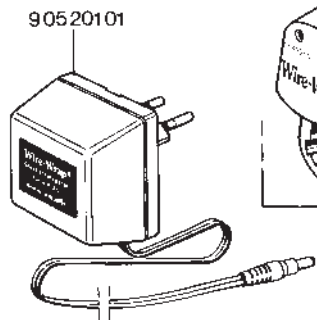
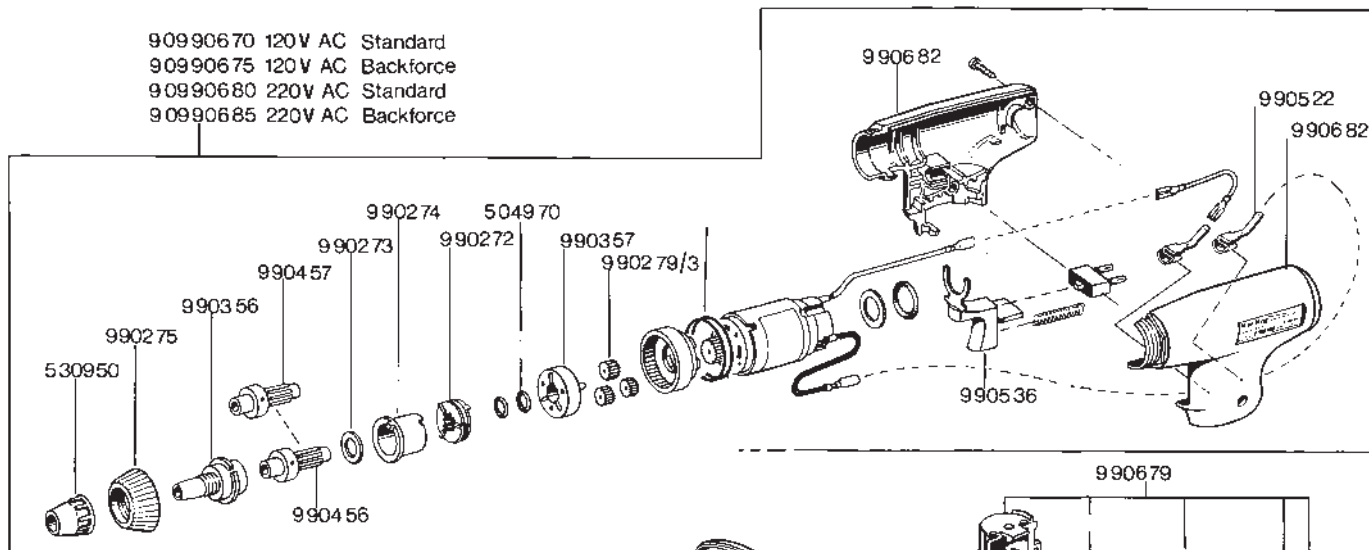

4D9R128/2

