

# Product datasheet

Specifications

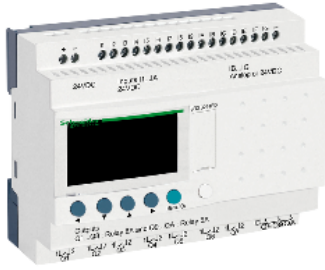

## modular smart relay Zelio Logic - 26 I/O - 24 V DC - clock - display

TSI code: 389538112 SR3B261BD

### Main

Range of product	Zelio Logic
Product or component type	Modular smart relay

### Complementary

Local display	With
Number of control scheme lines	0...500 with FBD programming 0...240 with ladder programming
Cycle time	6...90 ms
Backup time	10 years at 25 °C
Clock drift	12 min/year at 0...55 °C 6 s/month at 25 °C
Checks	Program memory on each power up
[Us] rated supply voltage	24 V
Supply voltage limits	19.2...30 V
Maximum supply current	190 mA (without extension) 300 mA (with extensions)
Power dissipation in W	10 W with extensions 6 W without extension
Reverse polarity protection	With
Discrete input number	16 conforming to EN/IEC 61131-2 type 1
Discrete input type	Resistive
Discrete input voltage	24 V DC
Discrete input current	4 mA
Counting frequency	1 kHz for discrete input
Voltage state 1 guaranteed	>= 15 V for I1...IA and IH...IR discrete input circuit >= 15 V for IB...IG used as discrete input circuit
Voltage state 0 guaranteed	<= 5 V for I1...IA and IH...IR discrete input circuit <= 5 V for IB...IG used as discrete input circuit
Current state 1 guaranteed	>= 1.2 mA (IB...IG used as discrete input circuit) >= 2.2 mA (I1...IA and IH...IR discrete input circuit)
Current state 0 guaranteed	<= 0.5 mA (IB...IG used as discrete input circuit) <= 0.75 mA (I1...IA and IH...IR discrete input circuit)
Input compatibility	3-wire proximity sensors PNP for discrete input
Analogue input number	6

<b>Analogue input type</b>	Common mode
<b>Analogue input range</b>	0...10 V 0...24 V
<b>Maximum permissible voltage</b>	30 V for analogue input circuit
<b>Analogue input resolution</b>	8 bits
<b>LSB value</b>	39 mV for analogue input circuit
<b>Conversion time</b>	Smart relay cycle time for analogue input circuit
<b>Conversion error</b>	+/- 5 % at 25 °C for analogue input circuit +/- 6.2 % at 55 °C for analogue input circuit
<b>Repeat accuracy</b>	+/- 2 % at 55 °C for analogue input circuit
<b>Operating distance</b>	10 m between stations, with screened cable (sensor not isolated) for analogue input circuit
<b>Input impedance</b>	12 kOhm for IB...IG used as analogue input circuit 12 kOhm for IB...IG used as discrete input circuit 7.4 kOhm for I1...IA and IH...IR discrete input circuit
<b>Number of outputs</b>	10 relay
<b>Output voltage limits</b>	24...250 V AC (relay output) 5...30 V DC (relay output)
<b>Contacts type and composition</b>	NO for relay output
<b>Output thermal current</b>	5 A for 2 outputs for relay output 8 A for 8 outputs for relay output
<b>Electrical durability</b>	AC-12: 500000 cycles at 230 V, 1.5 A for relay output conforming to EN/IEC 60947-5-1 AC-15: 500000 cycles at 230 V, 0.9 A for relay output conforming to EN/IEC 60947-5-1 DC-12: 500000 cycles at 24 V, 1.5 A for relay output conforming to EN/IEC 60947-5-1 DC-13: 500000 cycles at 24 V, 0.6 A for relay output conforming to EN/IEC 60947-5-1
<b>Switching capacity in mA</b>	>= 10 mA at 12 V (relay output)
<b>Operating rate in Hz</b>	0.1 Hz (at Ie) for relay output 10 Hz (no load) for relay output
<b>Mechanical durability</b>	10000000 cycles for relay output
<b>[Uimp] rated impulse withstand voltage</b>	4 kV conforming to EN/IEC 60947-1 and EN/IEC 60664-1
<b>Clock</b>	With
<b>Response time</b>	10 ms (from state 0 to state 1) for relay output 5 ms (from state 1 to state 0) for relay output
<b>Connections - terminals</b>	Screw terminals, 1 x 0.2...1 x 2.5 mm <sup>2</sup> (AWG 25...AWG 14) semi-solid Screw terminals, 1 x 0.2...1 x 2.5 mm <sup>2</sup> (AWG 25...AWG 14) solid Screw terminals, 1 x 0.25...1 x 2.5 mm <sup>2</sup> (AWG 24...AWG 14) flexible with cable end Screw terminals, 2 x 0.2...2 x 1.5 mm <sup>2</sup> (AWG 24...AWG 16) solid Screw terminals, 2 x 0.25...2 x 0.75 mm <sup>2</sup> (AWG 24...AWG 18) flexible with cable end
<b>Tightening torque</b>	0.5 N.m
<b>Overvoltage category</b>	III conforming to EN/IEC 60664-1
<b>Net weight</b>	0.4 kg

## Environment

<b>Immunity to microbreaks</b>	1 ms
<b>Product certifications</b>	GL C-Tick CSA UL GOST
<b>Standards</b>	EN/IEC 61000-4-2 level 3 EN/IEC 61000-4-5 EN/IEC 61000-4-6 level 3 EN/IEC 61000-4-11 EN/IEC 61000-4-3 EN/IEC 60068-2-27 Ea EN/IEC 61000-4-12 EN/IEC 60068-2-6 Fc EN/IEC 61000-4-4 level 3
<b>IP degree of protection</b>	IP20 (terminal block) conforming to IEC 60529

IP40 (front panel) conforming to IEC 60529

<b>Environmental characteristic</b>	EMC directive conforming to EN/IEC 61000-6-2 EMC directive conforming to EN/IEC 61000-6-3 EMC directive conforming to EN/IEC 61000-6-4 EMC directive conforming to EN/IEC 61131-2 zone B Low voltage directive conforming to EN/IEC 61131-2
<b>Disturbance radiated/ conducted</b>	Class B conforming to EN 55022-11 group 1
<b>Pollution degree</b>	2 conforming to EN/IEC 61131-2
<b>Ambient air temperature for operation</b>	-20...40 °C in non-ventilated enclosure conforming to IEC 60068-2-1 and IEC 60068-2-2 -20...55 °C conforming to IEC 60068-2-1 and IEC 60068-2-2
<b>Ambient air temperature for storage</b>	-40...70 °C
<b>Operating altitude</b>	2000 m
<b>Maximum altitude transport</b>	3048 m
<b>Relative humidity</b>	95 % without condensation or dripping water

## Packing Units

<b>Unit Type of Package 1</b>	PCE
<b>Number of Units in Package 1</b>	1
<b>Package 1 Weight</b>	381 g
<b>Package 1 Height</b>	6.8 cm
<b>Package 1 width</b>	10 cm
<b>Package 1 Length</b>	13.5 cm
<b>Unit Type of Package 2</b>	S03
<b>Number of Units in Package 2</b>	20
<b>Package 2 Weight</b>	8.146 kg
<b>Package 2 Height</b>	30 cm
<b>Package 2 width</b>	30 cm
<b>Package 2 Length</b>	40 cm

## Offer Sustainability

<b>Sustainable offer status</b>	Green Premium product
<b>REACH Regulation</b>	<a href="#">REACH Declaration</a>
<b>EU RoHS Directive</b>	Pro-active compliance (Product out of EU RoHS legal scope) <a href="#">EU RoHS Declaration</a>
<b>Mercury free</b>	Yes
<b>RoHS exemption information</b>	<a href="#">Yes</a>
<b>China RoHS Regulation</b>	<a href="#">China RoHS declaration</a>
<b>Environmental Disclosure</b>	<a href="#">Product Environmental Profile</a>
<b>Circularity Profile</b>	<a href="#">End of Life Information</a>
<b>WEEE</b>	The product must be disposed on European Union markets following specific waste collection and never end up in rubbish bins
<b>PVC free</b>	Yes

## Contractual warranty

<b>Warranty</b>	18 months
-----------------	-----------

**Compact and Modular Smart Relays**

**Mounting on 35 mm/1.38 in. DIN Rail**

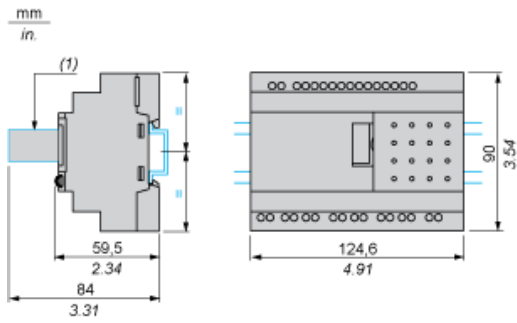

(1) With SR2USB01 or SR2BTC01

**Screw Fixing (Retractable Lugs)**

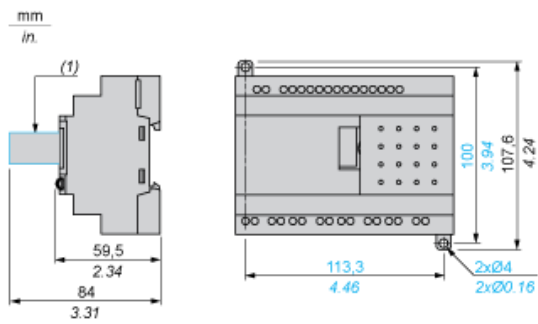

(1) With SR2USB01 or SR2BTC01

**Position of Display**

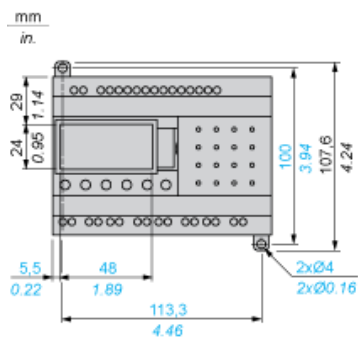

**Compact and Modular Smart Relays**

**Connection of Smart Relays on DC Supply**

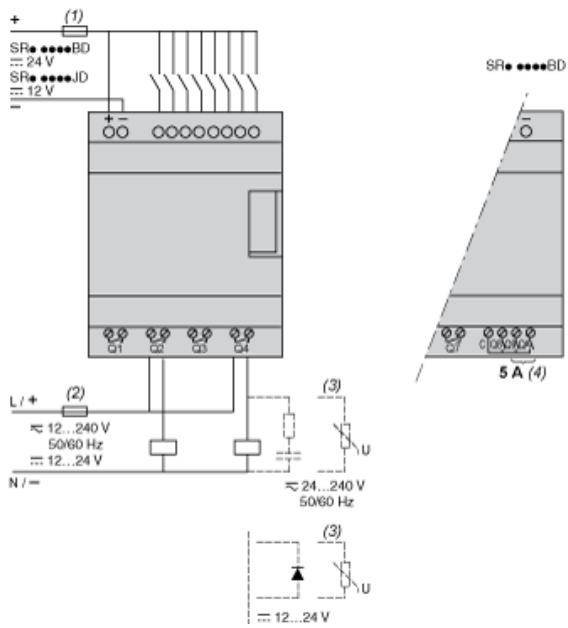

- (1) 1 A quick-blow fuse or circuit-breaker.
- (2) Fuse or circuit-breaker.
- (3) Inductive load.
- (4) Q9 and QA: 5 A (max. current in terminal C: 10 A).

**Discrete Input Used for 3-Wire Sensors**

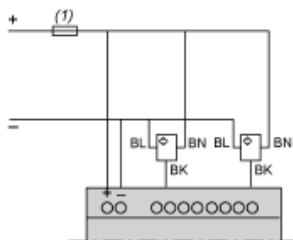

- (1) 1 A quick-blow fuse or circuit-breaker.

**Connection of Smart Relays on DC Supply**

**Analog Inputs**

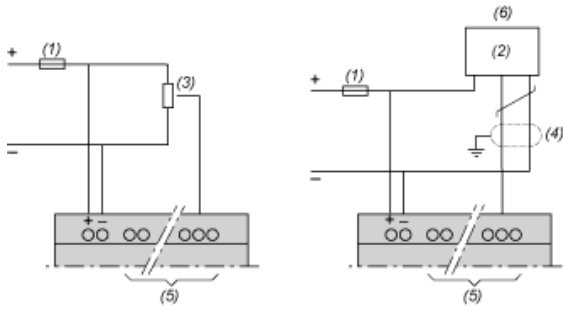

- (1) 1 A quick-blow fuse or circuit-breaker.
- (2) Ca: Analog sensor / Ta: Analog transmitter.
- (3) Recommended values: 2.2 kΩ / 0.5 W (10 kΩ max.)
- (4) Screened cables, maximum length 10 m / 32.80 feet.
- (5) Analog inputs according to Zelio Logic smart relay type (see table below)
- (6) 0-10 Vdc ANALOG

Smart Relays	Analog Inputs
SR2•12••D	IB...IE
SR2A201BD	IB and IC
SR2D201BD	IB and IC
SR2B20••D	IB...IG
SR2E201BD	IB...IG
SR3B10•BD	IB...IE
SR3B26••D	IB...IG

**Connection of Smart Relays on DC Supply, with Discrete I/O Extension Modules**

---

**SR3B...JD + SR3XT...JD, SR3B...BD + SR3XT...BD**

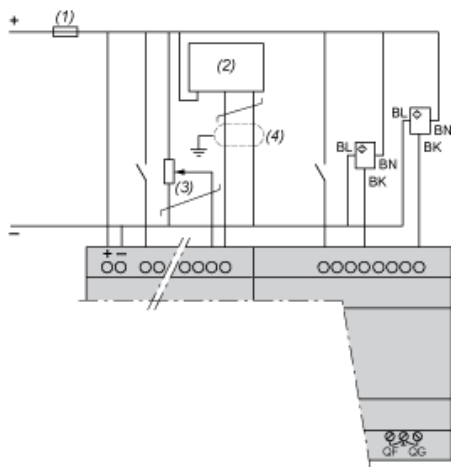

- (1) 1 A quick-blow fuse or circuit-breaker.
- (2) Ca: Analog sensor / Ta: Analog transmitter.
- (3) Recommended values: 2.2 k $\Omega$  / 0.5 W (10 k $\Omega$  max.)
- (4) Screened cables, maximum length 10 m / 32.80 feet.

**NOTE:** QF and QG : 5 A for SR3XT141\*\*

**Compact and Modular Smart Relays**

**Electrical Durability of Relay Outputs**

(in millions of operating cycles, conforming to IEC/EN 60947-5-1)

DC-12 (1)

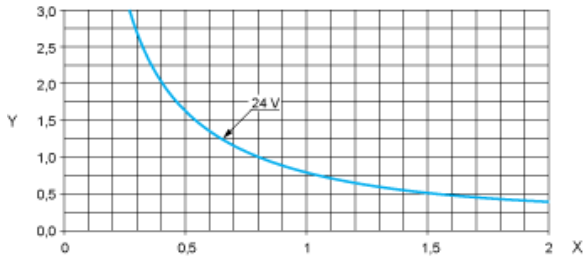

**X:** Current (A)  
**Y:** Millions of operating cycles  
**(1)** DC-12: control of resistive loads and of solid state loads isolated by opto-coupler,  $L/R \leq 1$  ms.

DC-13 (1)

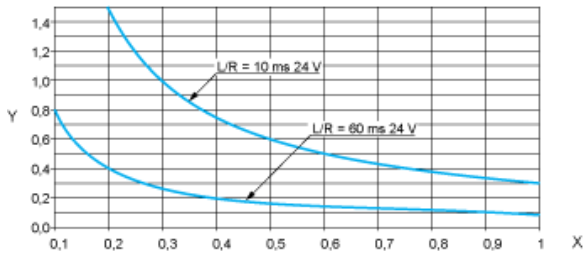

**X:** Current (A)  
**Y:** Millions of operating cycles  
**(1)** DC-13: switching electromagnets,  $L/R \leq 2 \times (U_e \times I_e)$  in ms,  $U_e$ : rated operational voltage,  $I_e$ : rated operational current (with a protection diode)